

**WEIDER**

**Weider**  
ARCHITECTURAL HARDWARE

# TOUGHENED GLASS FITTING SYSTEMS



Today's architectural designers demand high quality and high performance, yet they need flexibility to complement a wide range of building styles and decors.

Weider fittings offer the best design for frameless toughened glass door systems, that will enhance any building, new or old.

Weider Glass range presents you with a variety of accessories in this brochure. The range consists of full range of patch fitting corner brackets, accessories, floor spring and concealed transom door closer. In all the popular architectural finishes which make things easier for architects, interior designers and fabricators.

The Weider Hydraulic range conforms to most recognised international standards and complies with the requirements and/or recommendations of the following:

BS 476/22:87	— United Kingdom
(included in fire test)	— United States of America
UL	— United States of America
ULC	— Canada
CSIRC	— Australia
SISIR	— Singapore

**PROJECT REFERENCE**

GUANGZHOU FREE TRADE ZONE	- GUANGZHOU, CHINA
MUSEUM PURNA BHAKTIPERTIWI	- JAKARTA, INDONESIA
SENAYAN MALL	- JAKARTA, INDONESIA
HAPPAY WORLD HOUSE	- MAURITIUS
NEW WORLD CENTRE	- JOHOR BAHRU, MALAYSIA
WISMA HICOM	- KUALA LUMPUR, MALAYSIA
APOLLO CENTRE	- SINGAPORE
THE CONCOURSE	- SINGAPORE
CHAO CHU KANG	- SINGAPORE
NEIGHBOURHOOD CENTRE	- SINGAPORE
LIANG COURT	- SINGAPORE
ORCHARD TOWER	- SINGAPORE
ORCHID COUNTRY CLUB	- SINGAPORE

**Contents**

• Typical toughened glass assemblies with patch fittings and patch locks	2
• Maximum security for Weider patch fittings and locks	4
• WEIDER Floor spring and concealed transom closer	5
• WEIDER Patch fittings	6
• WEIDER Angled connector	10
• WEIDER Patch lock system	12
• WEIDER Accessories for patch fittings	18
• WEIDER Door rail system	19
• WEIDER Security key cylinder	20
• WEIDER WGL series Horizontal glass door furniture deadbolt system	21
• Typical toughened glass assemblies with patch fittings and WEIDER Glass locks	22
• WEIDER WGL 6300 series Full edge horizontal deadbolt locks	23
• WEIDER WGL series Horizontal glass door furniture latchbolt system	25
• WEIDER WGL 6306 series Full edge horizontal latchbolt locks	27
• WEIDER WGL 6200 series Notch edge horizontal latchbolt locks	29
• WEIDER Accessories for hinge doors and tempered glass doors	31
• WEIDER Entrance handles	32
• WEIDER Squash fitting system	34

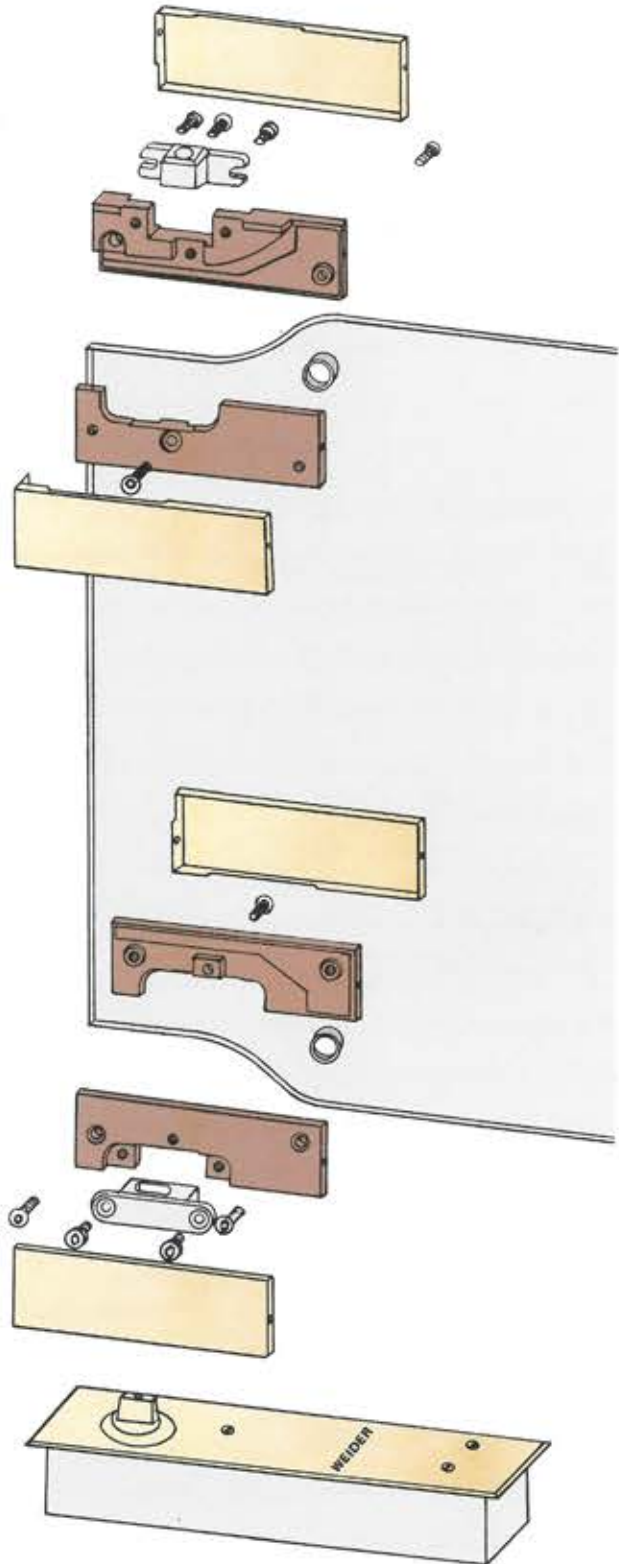

**WEIDER**

**Glass Fitting System**

**Examples of Tempered Glass Entrance**

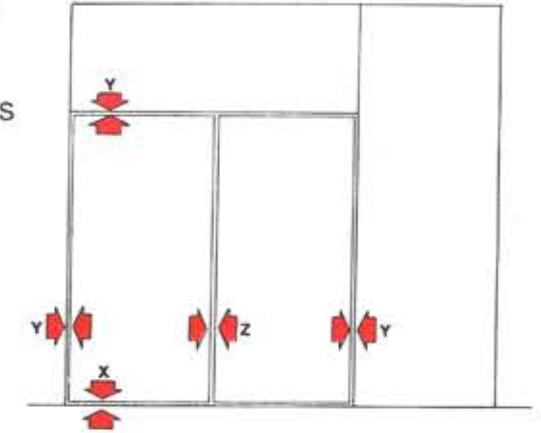
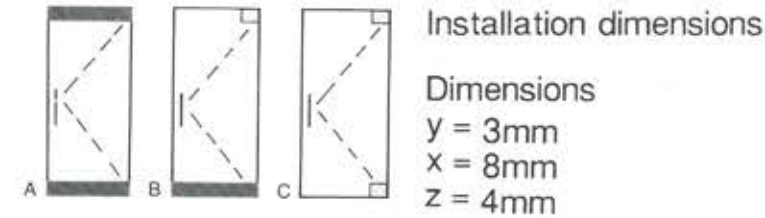

**Type A — Full width rails fitted along top and bottom edges**

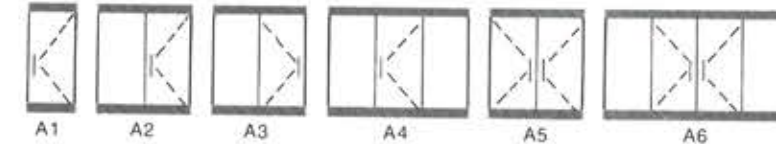

**Type B — Full width rail fitted along bottom edge only, patch fitted at top corner**

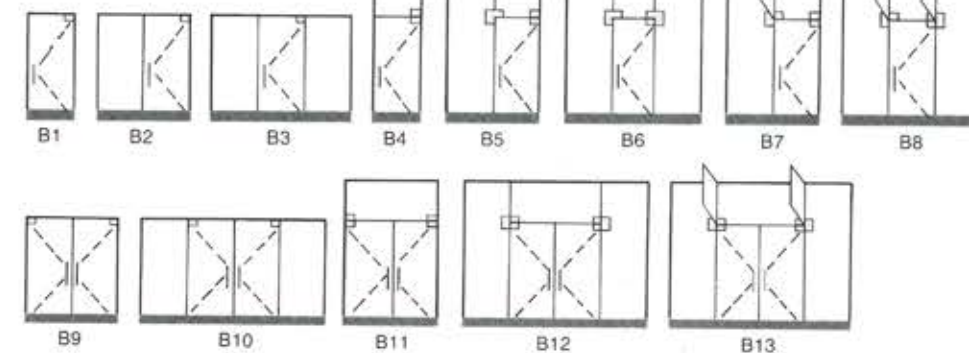

**Type C — Patches fitted at top and bottom corners**

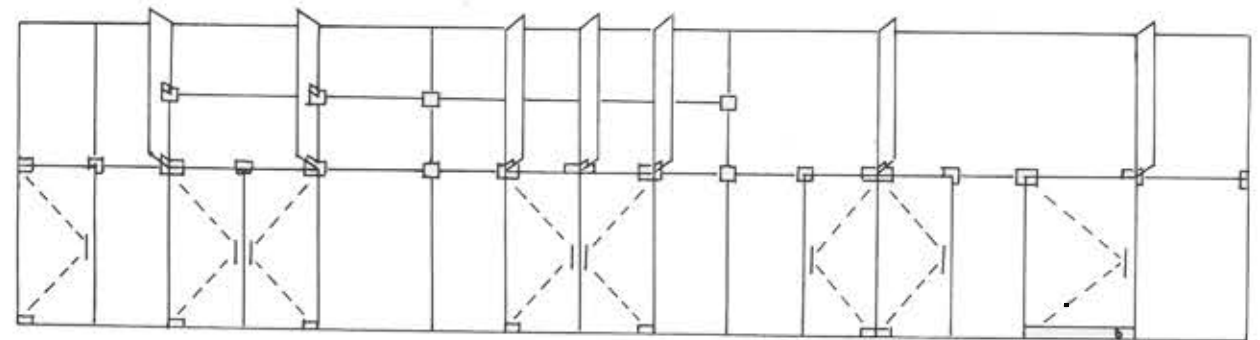
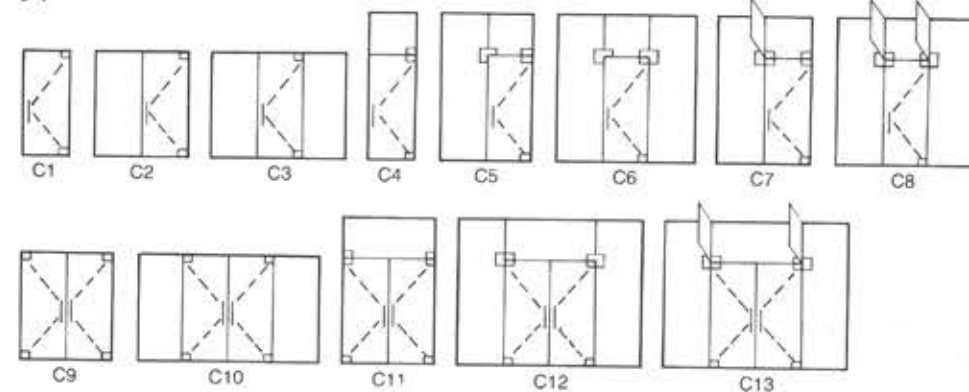

**• GUARANTEE**

The Weider products are guaranteed for 18 mth from the date of manufacture against defect in material and workmanship. Defective products will be replaced with a new unit, but no claims for damage incurred or work done thereon will be accepted. This guarantee is void if the product has been subjected to misapplication or abuse.



# WEIDER

## Glass Fitting System

**Weider**  
ARCHITECTURAL HARDWARE

The Weider-Glass Fittings advantages lie not just in their inherent beauty but also in their innovative design.

The Weider offers a high degree of security & strength. As you go through this information leaflet, you will find meticulous attention to detail: an uncompromising standard of quality and most importantly..... simple elegance and functionality.

### Weider fitting design features

- Precision cast and powder coated bodies for durability.
- Positive mechanical fixing through holes in glass to prevent the fittings releasing from the glass after a period of time.
- Internal assembly fixing features provide security.
- Coverplates are removable to minimise on-site damage. The doors can be assembled without the covers and they can be fitted at the completion of the project. Maintenance costs are also reduced if the covers get damaged as new ones are easily fitted.
- Interchangeable coverplates in wide range of finishes to meet the initial design decor, or any future decor as required.
- **Door controls.** All accessories have connections to Weider hydraulic floor closers and Weider 8800 series of concealed transom door closers.
- **Service.** A full technical service by Weider consultants department who can help with design and application plus before and after sales service.
- **Ordering System** - Please specify the following details.

#### A. Patch Fittings

Type/Art. NO. \_\_\_\_\_  
 Glass thickness: \_\_\_\_\_  
 Finish: \_\_\_\_\_

#### B. Patchlock

Type/Art. NO. \_\_\_\_\_  
 Glass thickness: \_\_\_\_\_  
 Finish: \_\_\_\_\_

Stainless steel or Wood door frame: (give diagram)

#### C. Floor spring/Conceal and transom door closer

Type/Art. NO. \_\_\_\_\_  
 Size/Closing force: \_\_\_\_\_  
 Finish: \_\_\_\_\_

#### D. Door rails/Rail cover

Type/Art. NO. \_\_\_\_\_  
 Door width: \_\_\_\_\_  
 Glass thickness: \_\_\_\_\_  
 Finishes: \_\_\_\_\_

#### • Finishes for Durability & Versatility.

The coverplates for the Weider Fittings are virtually maintenance free and are available in following finishes:

- Polished Stainless Steel. -PSS
- Satin Stainless Steel. -SSS
- Polished Brass. -PB
- Titanium Plated. -T I
- 24K Gold Plated. -24K
- Aluminium Mill Finish. -ML
- Satin Anodised Aluminium. -NA
- Dark Bronze Anodised Aluminium. -DB

- Powder-coated colours are available on request, but may be subject to extended delivery.

# WEIDER

**Weider**  
ARCHITECTURAL HARDWARE

### GLASS

All glass used in frameless glass door assemblies must be approved 10mm or 12mm toughened float safety glass. This can be altered by just changing the special compound gasket supplied with each clamp-on accessory.

Further more please indicate the glass thickness respectively the door and panel thickness 10 or 12mm. If the thickness is not mentioned. Fittings and locks for 12mm thickness will be supplied.

### DOORS



Recommended Maximum Sizes:

Glass Thickness	Height	Width
10mm – Patch Fittings	3000	x 1000mm
– Rails	3200	x 1150mm
12mm – Patch Fittings	3200	x 1000mm
– Rails	3500	x 1150mm

### MAXIMUM SECURITY FOR PATCH FITTINGS & LOCKS.

Large testing apparatus applies pressure in every direction to determining stress capacity, thus assuring the dependability of complete package in meeting or surpassing building codes and offering security.

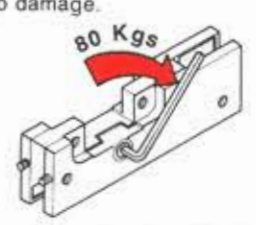
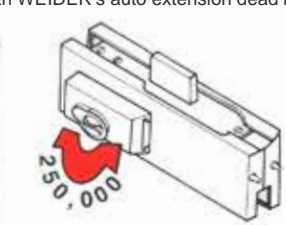
Weider glass fittings have passed various tests. The results are summarized below:

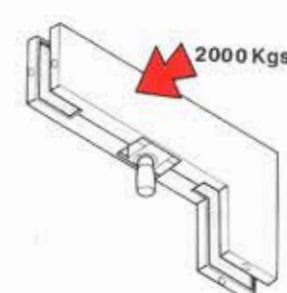
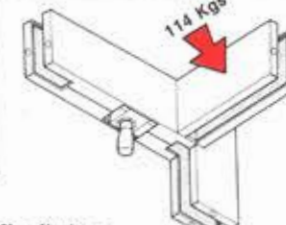
<p><b>Test 1: Torsion test.</b> A force of 80 Kgs was applied in the direction shown (the direction of force involved in the field when a force entered into the thread), after withstanding this load for 80 Kgs, the fitting's thread showed no damage.</p> 	<p><b>Test 2: Lock mechanism life cycle test.</b> The all Weider patch lock was subjected to 250,000 complete lock/unlock cycles of operation (approximately 50 years normal service). No adverse wear or change in the smooth operation of the lock could be found. Patented with WEIDER's auto extension dead bolt.</p> 	
<p><b>Test 3: Patch fittings life cycle test.</b> The Weider fittings was subjected to 500,000 complete open/close cycle of operation. No adverse wear or change in the smooth operation of the fittings could be found.</p> 	<p><b>Test 5: Horizontal load on patch fittings.</b> A force of 2000 Kgs was applied in the direction shown for five minutes. Examination again revealed no damage to the fittings or change in its function.</p> 	<p><b>Test 4: Horizontal load on fin fittings.</b> A force of 114 Kgs was applied in the direction shown. After withstanding this load for five minutes, the fin fittings showed no damage or change in its function.</p> 

### SIDE PANELS

Maximum available toughened glass size available from local safety glass manufacture for 10 or 12mm glass thickness is 3900 x 2080mm.

### FINS

Stablishing Fins are necessary to cope with loads imposed on a door assembly by the action of the door and external wind loads. The Fins must be securely fixed to a rigid structure at the top of the assembly.

**10mm glass** – when the width of the sidepanel (A) plus the height of the overpanel (B) exceeds a total of 1200mm a Fin is required, but not necessary if (A) or (B) is less than 400mm.

**12mm glass** – when the width of the sidepanel (A) plus the height of the overpanel (B) exceeds a total of 1500mm a Fin is required, but not necessary if (A) or (B) is less than 500mm.

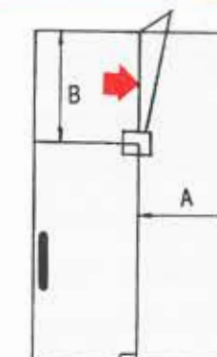

Weider Metal Inc. reserves the right to make product changes and is not responsible for obsolete template errors. To ensure your template is current, please visit our website at [www.weidermetal.com](http://www.weidermetal.com) or email our sales representatives.

© 2015 Weider Metal Inc. All rights reserved. WEIDER METAL AUSTRALIA. WEIDER METAL INC.



# WEIDER Door Rail System

The Weider Door Rail and sidepanel are designed 76.5mm (3") high. (Suitable for 10-12mm glass thickness). Other design or glass thickness are available but on request.

For centre pivoted double action doors, Standard length 1000 mm.

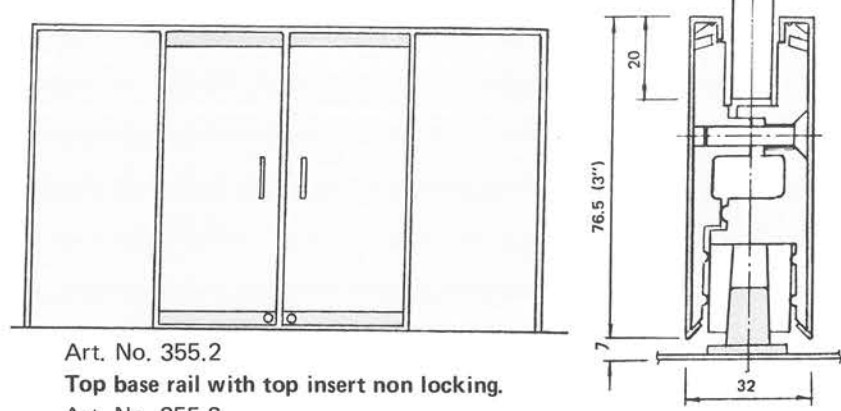
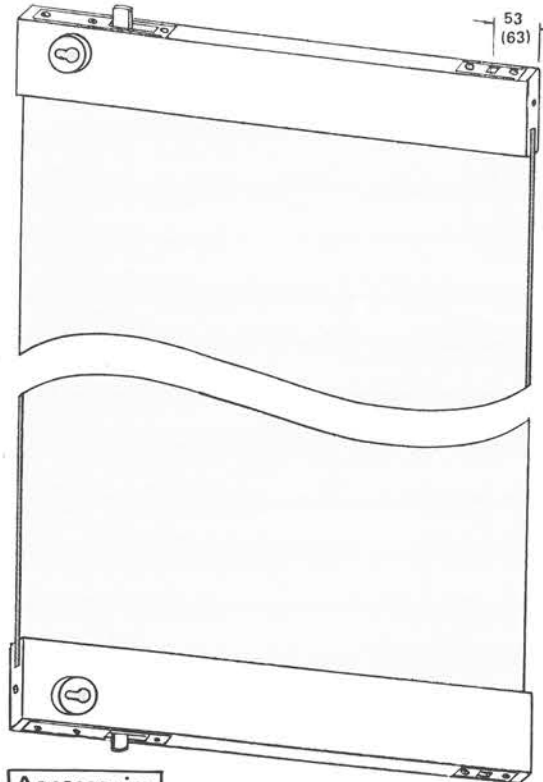

- Art. No. 355.2  
Top base rail with top insert non locking.
- Art. No. 355.3  
Bottom base rail with bottom insert non locking.
- Art. No. 355.4  
Top base rail with top insert, locking for profile cylinder.
- Art. No. 355.5  
Bottom base rail with bottom insert, locking for profile cylinder.
- Art. No. 355.6  
Top base rail with top insert, locking for Weider 5900 lock or others.
- Art. No. 355.7  
Bottom base rail with bottom insert, locking for Weider 5900 lock or others.

Please specify locking combination.  
 Key lock both side.  
 Key lock one side only.  
 Key lock one side, Thumb turn on other side.

- Art. No. 355.1  
Top and bottom sidepanel base rail.
- Art. No. 355.12  
Base rail 250 mm, length lock section without lock.
- Art. No. 355.13  
Base rail 250 mm, length lock section with profile cylinder.
- Art. No. 355.14  
Base rail 250 mm, length lock section prepared for special lock.
- Art. No. 355.22  
All base rails are supplied in natural anodized aluminium.
- Art. No. 355.23  
Rail cover-stock length 1000mm.  
Rail cover – stock length, prepared for lock.

Ordering System – Please specify the following details

1. Door leaf/Frame/Base Rail.  
Glass thickness: \_\_\_\_\_  
Type/Art. No. \_\_\_\_\_
2. Lock mechanism:  
Type/Art. No. \_\_\_\_\_
3. Rail cover  
Finishes: \_\_\_\_\_
4. End caps.  
Finishes \_\_\_\_\_
5. Cylinder escutcheon  
Finishes \_\_\_\_\_

## Accessories

- Art. No. 725-502  
Top insert for concealed overhead Transom door closer
- Art. No. 725-503  
Top insert pivot center
- Art. No. 725-504  
Bottom insert for Weider floor spring or floor bearing
- Art. No. 725-32  
End cap for door rail
- Art. No. 725-100  
Easy clean socket
- Art. No. ES-46  
Easy clean socket
- Art. No. 1801  
Swing Deadlock for door rail
- Art. No. 725-502  
Heavy duty floor pivot Bearing.
- Art. No. 725-100  
Easy clean socket
- Art. No. ES-46  
Easy clean socket
- Art. No. 1801  
Swing Deadlock for door rail

# WEIDER Security Key Cylinder

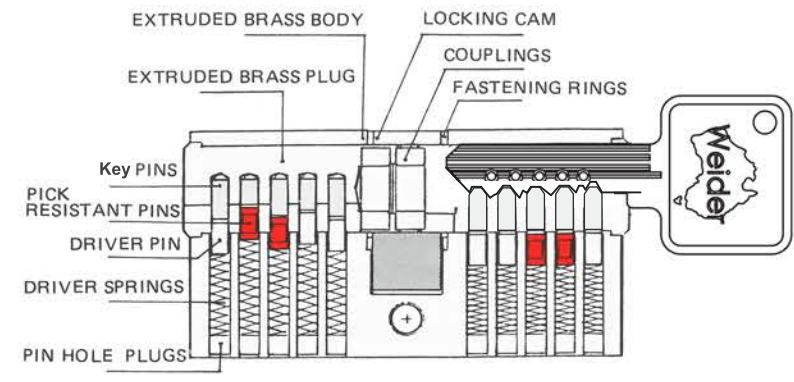

## \*Security

The Weider Key cylinders produces with the cam 20° off center, thus increasing considerably of the Weider cylinder, in fact the cylinder can not be pulled out of the locks without using the proper key to bring the cam into vertical position.

## \*Keying

The Weider Key cylinder available in:  
 Keyed-alike pairs (KA) (KA2)  
 Keyed-different (KD)  
 Keyed-alike sets of 50 (KA50)  
 for special keying on request.

## Weider Profile Key Cylinder

- pin tumblers 5 (if necessary 6) Up to 16 Pins
- number of keys 3
- total length see drawing
- extensions one or two sides, up by 5 mm at each step
- locking nose 9 mm for normal heights
- key turn 360°
- material cylinder: brass, knob zinc die cast.
- finish cylinder and knob dull nickel, special finish on request

- Accessories:  
1 screw M5

• Please note:  
 within masterkey or key Alike available. installations both types can be combined with Art. No. 603-S and Art. No. 603-ST as well.

Art. No.	L	A	B
603-S	60	25	25
603-ST	70	30	30
603-SH	40	25	4
603-T	40	25	4

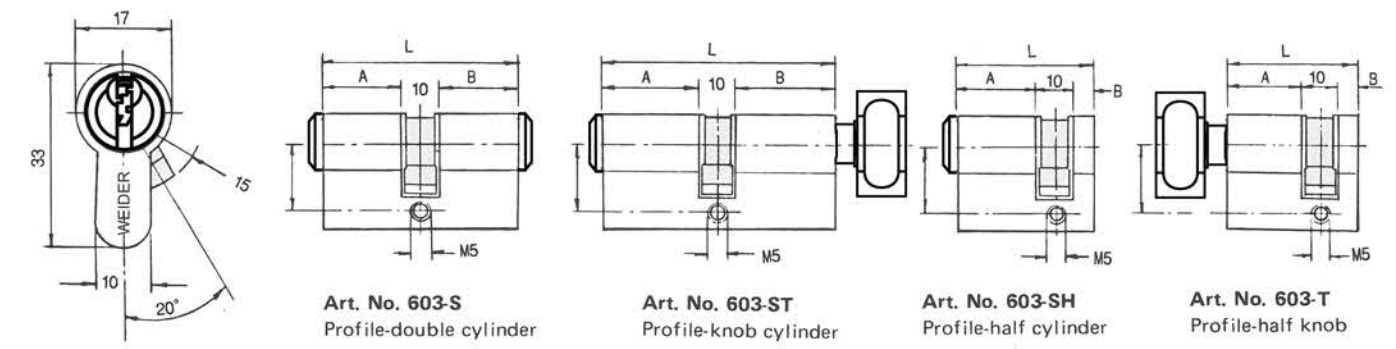

## Weider 502 Oval Key Cylinder

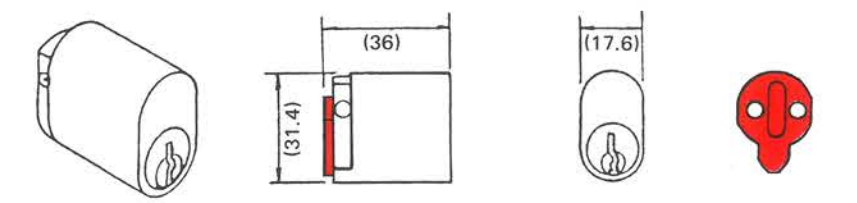

## 502 Oval cylinder

- Extruded brass body and plugs.
- Pin tumbler system.
- Brass pins.
- Antipicking brass driver pins.
- Phosphor bronze springs.
- Key turn: 360°.
- Keyway: Lockwood C-4.
- 2 keys.
- Standard Finishes: Chrome plated, Satin chrome, Polished brass, Dark bronze.

## Weider 530 Mortise Key Cylinder

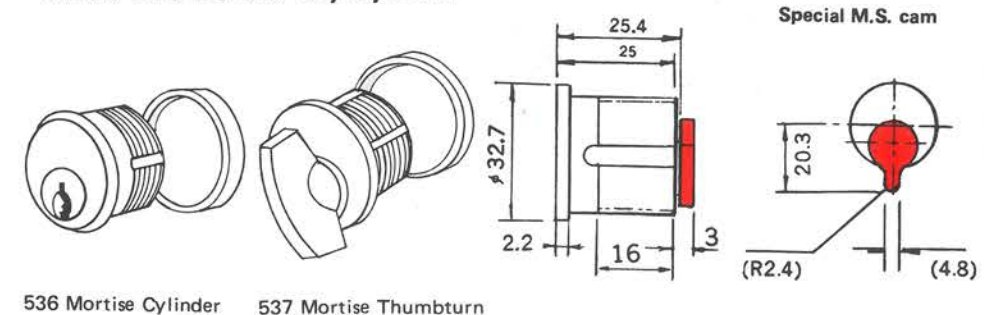

## 530 Mortise key cylinder

- Extruded brass body and plugs.
- Self-lubricating powdered steel cam.
- Pin tumbler system.
- 5 brass pins.
- Antipicking brass driver pins.
- Phosphor bronze springs.
- 2 brass nickel plated keys.
- Key/knob turn 360°.
- Available keyway & key broach:  
A: Yale. B: Schlage-C. C: Weiser.
- Standard Finishes:  
CP—Chrome plated. SC—Satin chrome.  
PB—Polished brass. DB—Dark bronze.



## WEIDER Maximum Security Patch Fittings

**International Patent Registered**



### Description

**Weider** Patch Fitting are easy to install and constructed with Stainless Steel Plate which is made durable. **Weider** hi-quality material and excellence workmanship guarantees a lift time service for durability for 3 years. Positive mechanical fixing through holes in glass to prevent the fittings releasing from the glass after a period of time. Internal assembly fixing feature provide security. Large testing apparatus applies pressure in every direction to determin stress capacity, thus assuring the dependability of complete package in meeting or surpassing codes and offering security.

### Features and Specifications

- Application: For swing doors.
- Durable Mechanism, Stainless Steel Cover plate
- Removeable cover plate to minimise on-site damage
- Torsion Test: 400KG
- Dialective Load on Bolt: 30KG
- Horizontal Load on Patch Fitting: 2000KG
- Life Cycle Test: 500,000 Cycle (Open/Close) (Approved by SISIR-Singapore)
- Lock Mechanism Life Cycle: 250,000 Cycle (Lock/Unlock)

Standard Finishes: Satin Stainless Steel (SSS), Polished Stainless Steel (PSS), Titanium Gold (TiG), Aluminium Siilver Brush (SNA)

\* Colour Conversion kit available upon request.

### GUARANTEE

The **WEIDER** Patch Fitting are guaranteed **3 years** from date of manufacture against any defects in material or workmanship. Defective products will be replaced with a new unit; but no claims for damage incurred or work done thereon will be allowed. This guarantee is void if the product has been subjected to misaplication or abuse.



Design by Weider Metal Australia



## WEIDER Maximum Security Patch Fittings

### WF-10 Bottom Patch Fitting Features and Specifications



#### Glass Preparation

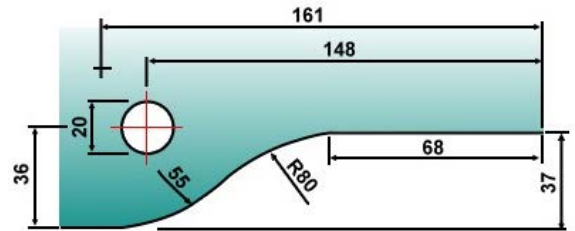

- Application: For swing doors.
- Durable Mechanism, Stainless Steel Cover plate
- Removeable cover plate to minimise on-site damage
- Torsion Test: 400KG
- Horizontal Load on Patch Fitting: 2000KG
- Glass Thickness: 10-12mm / 13.5-15mm
- L\*W\*H : L: 166mm, W: 52mm, H: 31mm
- Life Cycle Test: 500,000 Cycle (Open/Close) (Approved by SISIR-Singapore)

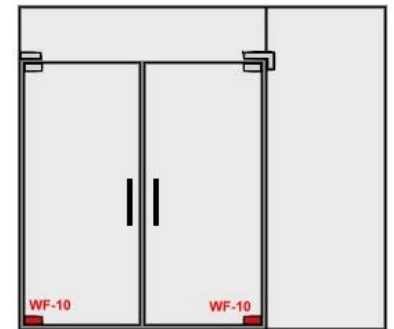

### WF-20 Top Patch Fitting Features and Specifications



#### Glass Preparation

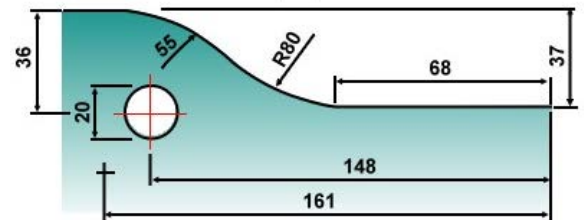

- Application: For swing doors.
- Durable Mechanism, Stainless Steel Cover plate
- Removeable cover plate to minimise on-site damage
- Torsion Test: 400KG
- Horizontal Load on Patch Fitting: 2000KG
- Glass Thickness: 10-12mm / 13.5-15mm
- L\*W\*H : L: 166mm, W: 52mm, H: 31mm
- Life Cycle Test: 500,000 Cycle (Open/Close) (Approved by SISIR-Singapore)

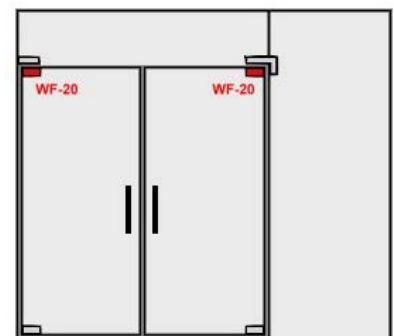

### GUARANTEE

The **WEIDER** Patch Fitting are guaranteed **3 years** from date of manufacture against any defects in material or workmanship. Defective products will be replaced with a new unit; but no claims for damage incurred or work done thereon will be allowed. This guarantee is void if the product has been subjected to misapplication or abuse.



## WEIDER Maximum Security Patch Fittings

**International Patent Registered**

### WF-30 Overpanel Pivot Patch Fitting Features and Specifications



#### Glass Preparation

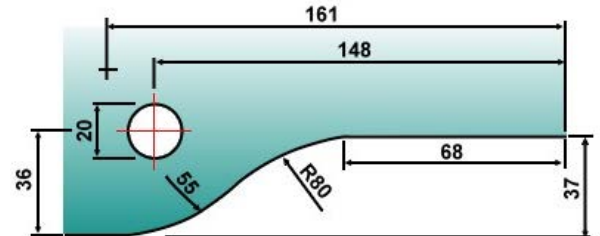

- Application: For swing doors.
- Durable Mechanism, Stainless Steel Cover plate
- Removeable cover plate to minimise on-site damage
- Torsion Test: 400KG
- Horizontal Load on Patch Fitting: 2000KG
- Glass Thickness: 10-12mm / 13.5-15mm
- L\*W\*H : L: 164mm, W: 52mm, H: 31mm
- Life Cycle Test: 500,000 Cycle (Open/Close) (Approved by SISIR-Singapore)

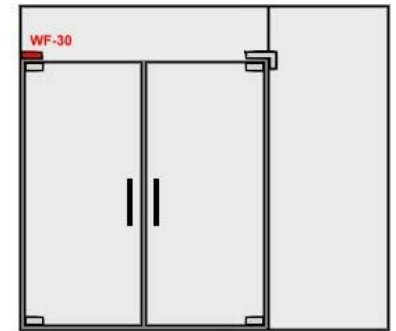

### WF-40 Overpanel to Sidepanel Pivot Patch Fitting Features and Specifications

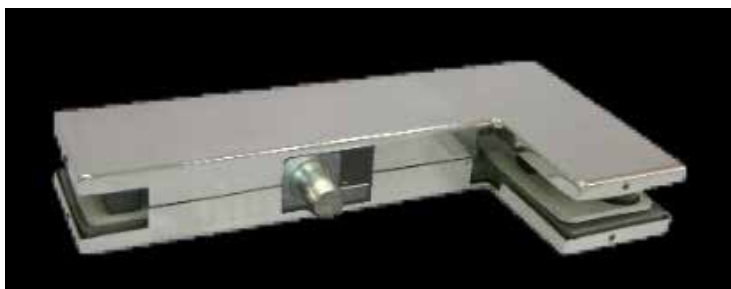

#### Glass Preparation

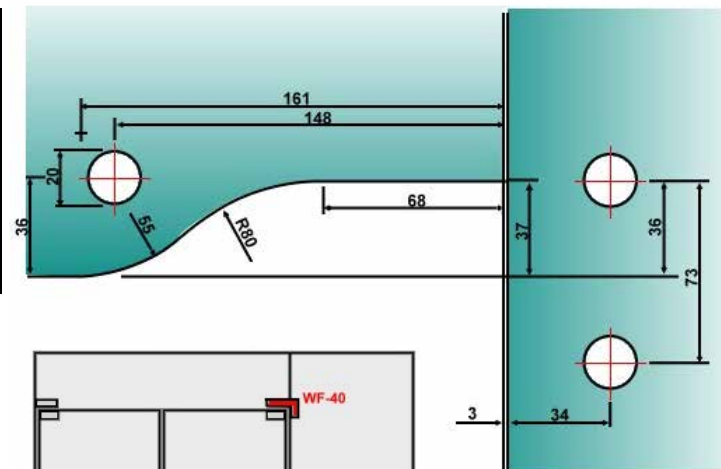

- Application: For swing doors.
- Durable Mechanism, Stainless Steel Cover plate
- Removeable cover plate to minimise on-site damage
- Torsion Test: 400KG
- Horizontal Load on Patch Fitting: 2000KG
- Glass Thickness: 10-12mm / 13.5-15mm
- L\*W\*H : L: 166mm, W: 52mm, H: 31mm
- Life Cycle Test: 500,000 Cycle (Open/Close) (Approved by SISIR-Singapore)

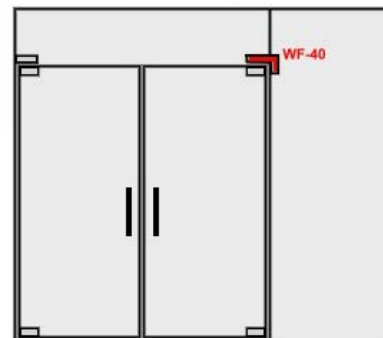

### GUARANTEE

The **WEIDER** Patch Fitting are guaranteed **3 years** from date of manufacture against any defects in material or workmanship. Defective products will be replaced with a new unit; but no claims for damage incurred or work done thereon will be allowed. This guarantee is void if the product has been subjected to misapplication or abuse.



Design by Weider Metal Australia



13-3

Weider Metal Inc. reserves the right to make product changes and is not responsible for obsolete template errors. To ensure your template is current, please visit our website at [www.weidermetal.com](http://www.weidermetal.com) or email our sales representatives.

© 2015 Weider Metal Inc. All rights reserved.  
WEIDER METAL AUSTRALIA. WEIDER METAL INC.



## WEIDER Maximum Security Patch Fittings

**International Patent Registered**

### WF-41-R/H Overpanel Pivot Patch Fitting including Fin Fitting Features and Specifications

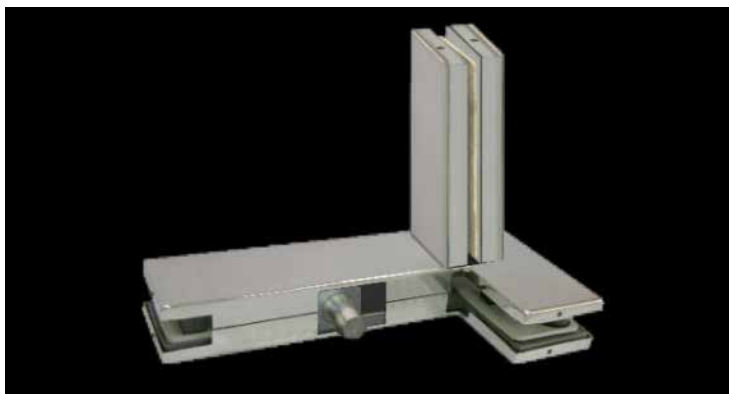

#### Glass Preparation

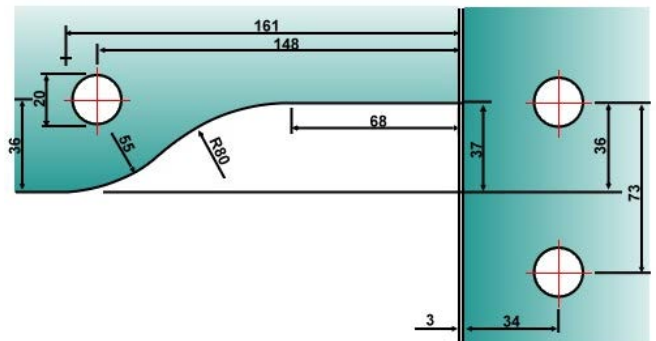

- Application: For swing doors.
- Durable Mechanism, Stainless Steel Cover plate
- Removeable cover plate to minimise on-site damage
- Torsion Test: 400KG
- Horizontal Load on Patch Fitting: 2000KG
- Glass Thickness: 10-12mm / 13.5-15mm
- L\*W\*H : L: 164mm, W: 52mm, H: 31mm
- Life Cycle Test: 500,000 Cycle (Open/Close) (Approved by SISIR-Singapore)

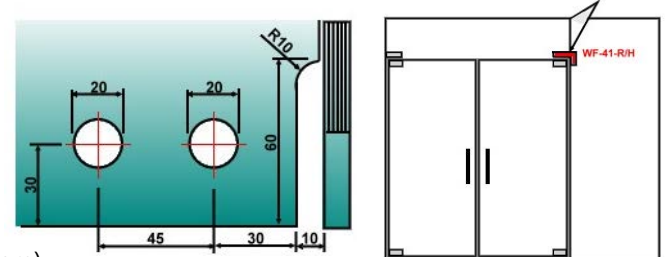

### WF-41-L/H Overpanel Pivot Patch Fitting including Fin Fitting Features and Specifications

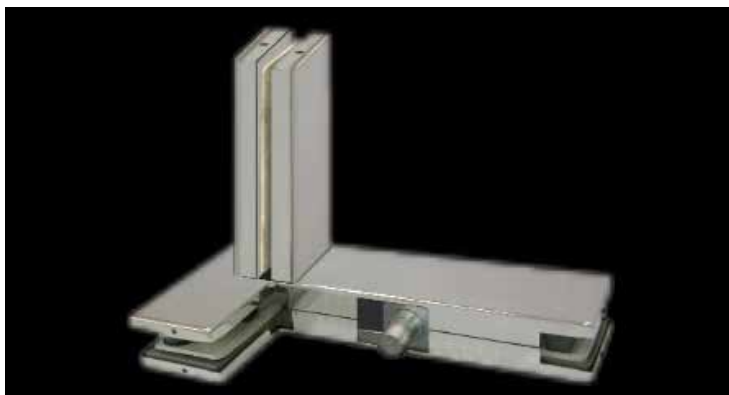

#### Glass Preparation

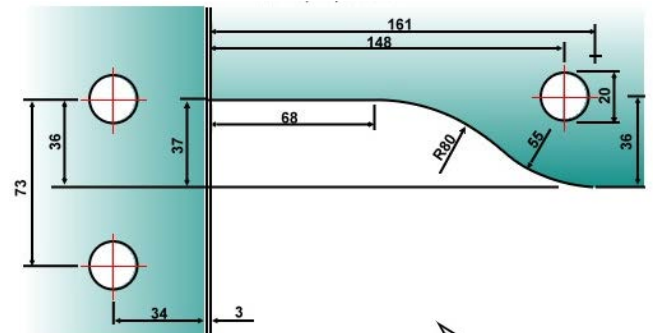

- Application: For swing doors.
- Durable Mechanism, Stainless Steel Cover plate
- Removeable cover plate to minimise on-site damage
- Torsion Test: 400KG
- Horizontal Load on Patch Fitting: 2000KG
- Glass Thickness: 10-12mm / 13.5-15mm
- L\*W\*H : 166mm \* 52mm \* 31mm
- Life Cycle Test: 500,000 Cycle (Open/Close) (Approved by SISIR-Singapore)

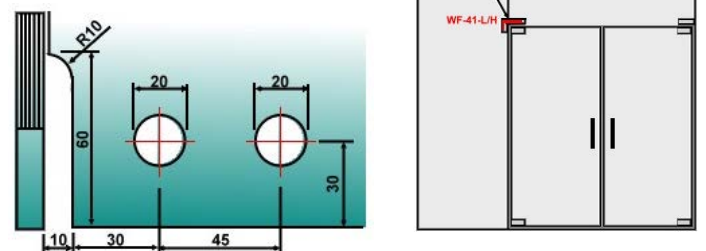

### GUARANTEE

The **WEIDER** Patch Fitting are guaranteed **3 years** from date of manufacture against any defects in material or workmanship. Defective products will be replaced with a new unit; but no claims for damage incurred or work done thereon will be allowed. This guarantee is void if the product has been subjected to misapplication or abuse.



Design by Weider Metal Australia



Weider Metal Inc. reserves the right to make product changes and is not responsible for obsolete template errors. To ensure your template is current, please visit our website at [www.weidermetal.com](http://www.weidermetal.com) or email our sales representatives.

© 2015 Weider Metal Inc. All rights reserved.  
WEIDER METAL AUSTRALIA. WEIDER METAL INC.





## WEIDER Maximum Security Patch Fittings

**International Patent Registered**

### WF-51 Fin Fitting (Back to Back doors complete with pivot and cover caps) Features and Specifications

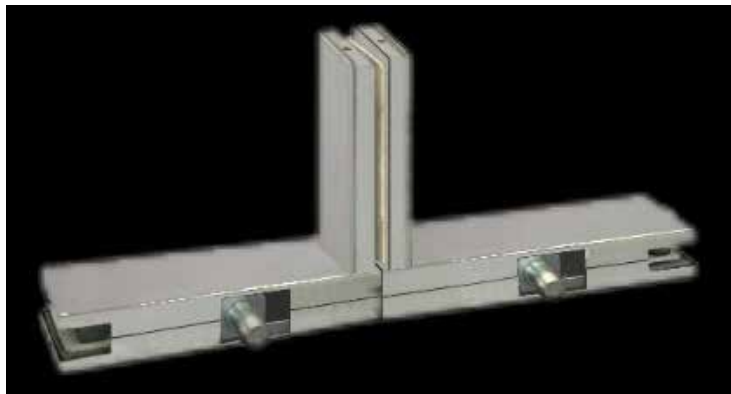

#### Glass Preparation

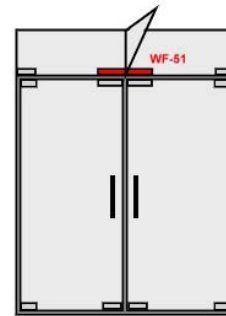
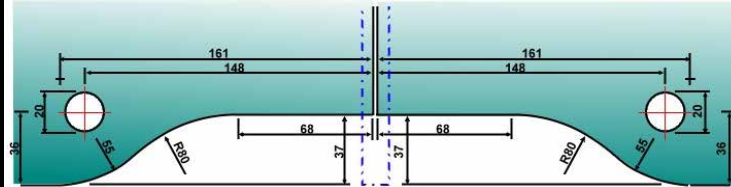

- Application: For swing doors.
- Durable Mechanism, Stainless Steel Cover plate
- Removeable cover plate to minimise on-site damage
- Torsion Test: 400KG
- Horizontal Load on Patch Fitting: 2000KG
- Glass Thickness: 10-12mm / 13.5-15mm
- L\*W\*H : L: 332mm, W: 52mm, H: 31mm
- Life Cycle Test: 500,000 Cycle (Open/Close) (Approved by SISIR-Singapore)

### WF-52 Overpanel Connector with Fin Fitting Features and Specifications

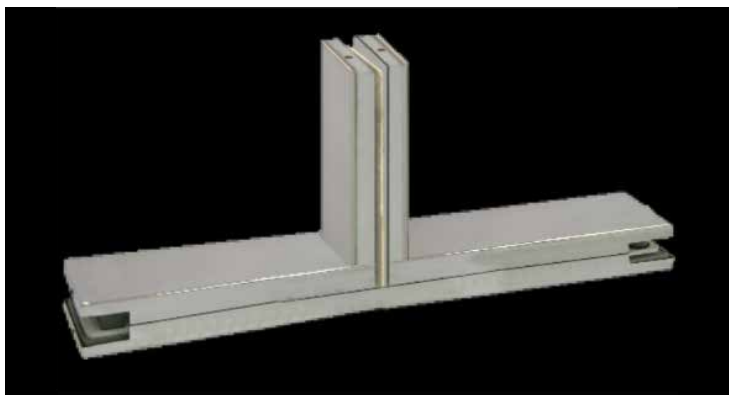

#### Glass Preparation

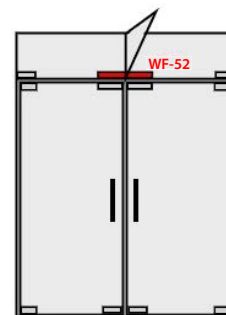
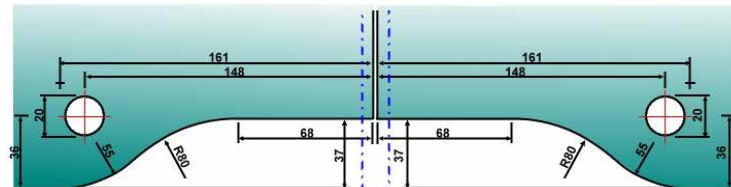

- Application: For swing doors.
- Durable Mechanism, Stainless Steel Cover plate
- Removeable cover plate to minimise on-site damage
- Torsion Test: 400KG
- Horizontal Load on Patch Fitting: 2000KG
- Glass Thickness: 10-12mm / 13.5-15mm
- L\*W\*H : L: 332mm, W: 52mm, H: 31mm
- Life Cycle Test: 500,000 Cycle (Open/Close) (Approved by SISIR-Singapore)

### GUARANTEE

The **WEIDER** Patch Fitting are guaranteed **3 years** from date of manufacture against any defects in material or workmanship. Defective products will be replaced with a new unit; but no claims for damage incurred or work done thereon will be allowed. This guarantee is void if the product has been subjected to misapplication or abuse.



Design by Weider Metal Australia

13-5

Weider Metal Inc. reserves the right to make product changes and is not responsible for obsolete template errors. To ensure your template is current, please visit our website at [www.weidermetal.com](http://www.weidermetal.com) or email our sales representatives.

© 2015 Weider Metal Inc. All rights reserved.  
WEIDER METAL AUSTRALIA. WEIDER METAL INC.



## WEIDER Maximum Security Patch Fittings

**International Patent Registered**

### WF-53 Fin Fitting Side Panel Patch Features and Specifications



#### Glass Preparation

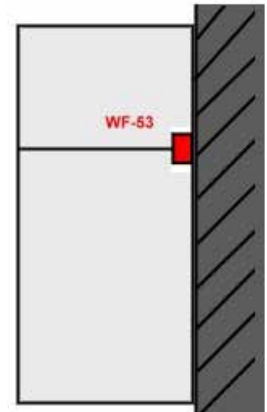
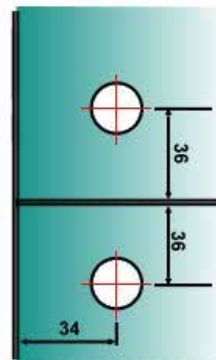

- Application: For swing doors.
- Durable Mechanism, Stainless Steel Cover plate
- Removeable cover plate to minimise on-site damage
- Torsion Test: 400KG
- Horizontal Load on Patch Fitting: 2000KG
- Glass Thickness: 10-12mm / 13.5-15mm
- L\*W\*H : L: 108mm, W: 52mm, H: 31mm
- Life Cycle Test: 500,000 Cycle (Open/Close) (Approved by SISIR-Singapore)

### WF-60/61 Overpanel to Sidepanel Patch Fitting Features and Specifications

#### Glass Preparation

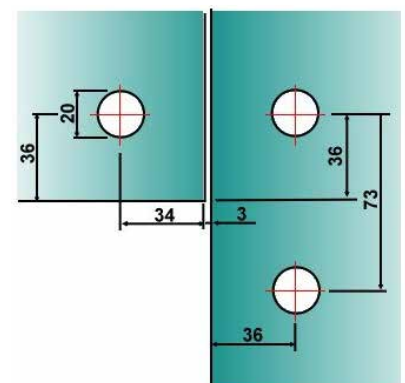

- Application: For swing doors.
- Durable Mechanism, Stainless Steel Cover plate
- Removeable cover plate to minimise on-site damage
- Torsion Test: 400KG
- Horizontal Load on Patch Fitting: 2000KG
- Glass Thickness: 10-12mm / 13.5-15mm
- L\*W\*H : L: 106mm, W: 52mm, H: 31mm
- Life Cycle Test: 500,000 Cycle (Open/Close) (Approved by SISIR-Singapore)

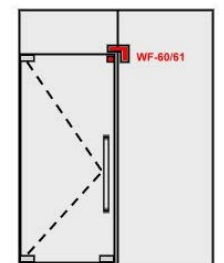

### GUARANTEE

The **WEIDER** Patch Fitting are guaranteed **3 years** from date of manufacture against any defects in material or workmanship. Defective products will be replaced with a new unit; but no claims for damage incurred or work done thereon will be allowed. This guarantee is void if the product has been subjected to misapplication or abuse.



Design by Weider Metal Australia



13-6

Weider Metal Inc. reserves the right to make product changes and is not responsible for obsolete template errors. To ensure your template is current, please visit our website at [www.weidermetal.com](http://www.weidermetal.com) or email our sales representatives.

© 2015 Weider Metal Inc. All rights reserved.  
WEIDER METAL AUSTRALIA. WEIDER METAL INC.



## WEIDER Maximum Security Patch Fittings

**International Patent Registered**

### WF-62 Special Patch Connection Fitting Features and Specifications

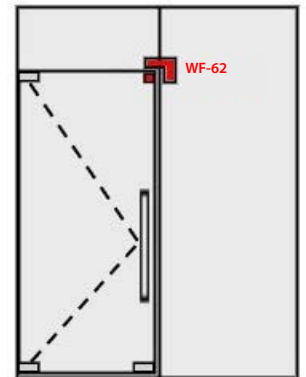
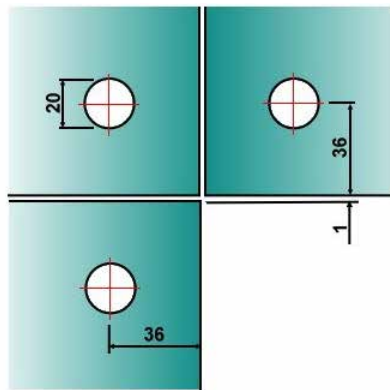

- Application: For swing doors.
- Durable Mechanism, Stainless Steel Cover plate
- Removeable cover plate to minimise on-site damage
- Torsion Test: 400KG
- Horizontal Load on Patch Fitting: 2000KG
- Glass Thickness: 10-12mm / 13.5-15mm
- L\*W\*H : L: 106mm, W: 52mm, H: 31mm
- Life Cycle Test: 500,000 Cycle (Open/Close) (Approved by SISIR-Singapore)

### WF-70 Overpanel Patch Fitting Features and Specifications

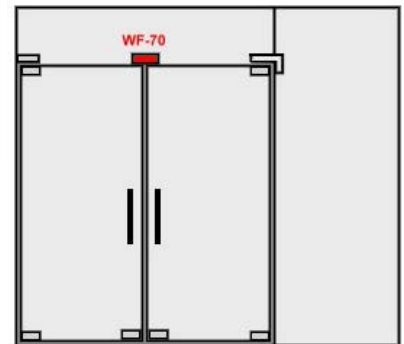
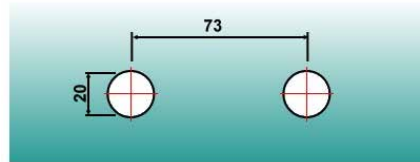

- Application: For swing doors.
- Durable Mechanism, Stainless Steel Cover plate
- Removeable cover plate to minimise on-site damage
- Torsion Test: 400KG
- Horizontal Load on Patch Fitting: 2000KG
- Glass Thickness: 10-12mm / 13.5-15mm
- L\*W\*H : L: 116mm, W: 52mm, H: 31mm
- Life Cycle Test: 500,000 Cycle (Open/Close) (Approved by SISIR-Singapore)

### GUARANTEE

The **WEIDER** Patch Fitting are guaranteed **3 years** from date of manufacture against any defects in material or workmanship. Defective products will be replaced with a new unit; but no claims for damage incurred or work done thereon will be allowed. This guarantee is void if the product has been subjected to misapplication or abuse.



Design by Weider Metal Australia



13-7

Weider Metal Inc. reserves the right to make product changes and is not responsible for obsolete template errors. To ensure your template is current, please visit our website at [www.weidermetal.com](http://www.weidermetal.com) or email our sales representatives.

© 2015 Weider Metal Inc. All rights reserved.  
WEIDER METAL AUSTRALIA. WEIDER METAL INC.



## WEIDER Maximum Security Patch Fittings

**International Patent Registered**

### WF-80 Special Patch Connection Fitting Features and Specifications

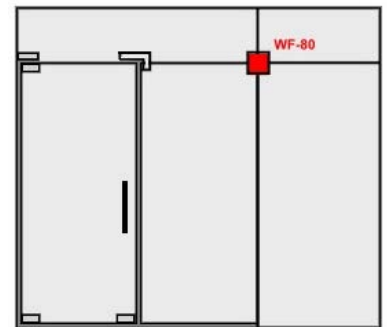
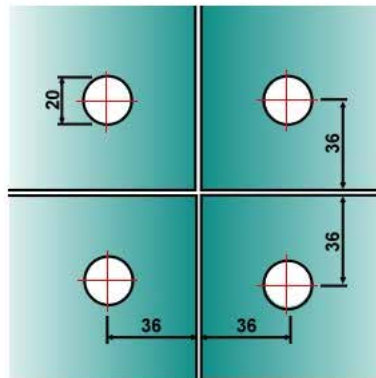

- Application: For swing doors.
- Durable Mechanism, Stainless Steel Cover plate
- Removeable cover plate to minimise on-site damage
- Torsion Test: 400KG
- Horizontal Load on Patch Fitting: 2000KG
- Glass Thickness: 10-12mm / 13.5-15mm
- L\*W\*H : L: 106mm, W: 106mm, H: 31mm
- Life Cycle Test: 500,000 Cycle (Open/Close) (Approved by SISIR-Singapore)

### WF-81 Special Patch Connection Fitting including Fin Fitting Features and Specifications

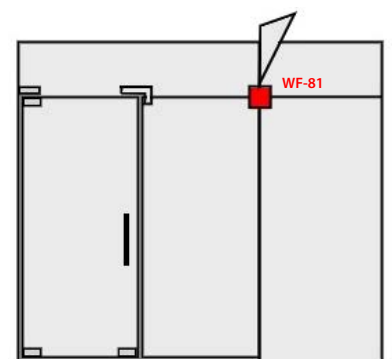
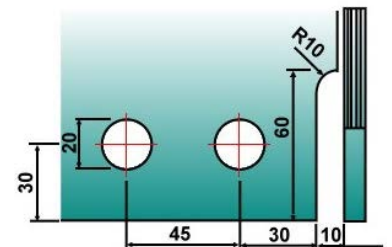
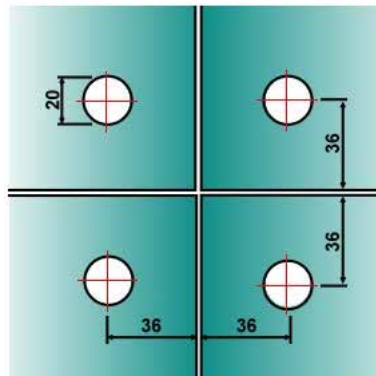

- Application: For swing doors.
- Durable Mechanism, Stainless Steel Cover plate
- Removeable cover plate to minimise on-site damage
- Torsion Test: 400KG
- Horizontal Load on Patch Fitting: 2000KG
- Glass Thickness: 10-12mm / 13.5-15mm
- L\*W\*H : L: 112mm, W: 52mm, H: 31mm
- Life Cycle Test: 500,000 Cycle (Open/Close) (Approved by SISIR-Singapore)

### GUARANTEE

The **WEIDER** Patch Fitting are guaranteed **3 years** from date of manufacture against any defects in material or workmanship. Defective products will be replaced with a new unit; but no claims for damage incurred or work done thereon will be allowed. This guarantee is void if the product has been subjected to misapplication or abuse.



Design by Weider Metal Australia





## WEIDER Maximum Security Patch Fittings

### International Patent Registered

### WF-82 Special Patch Connection Fitting including Double Fin Fitting Features and Specifications

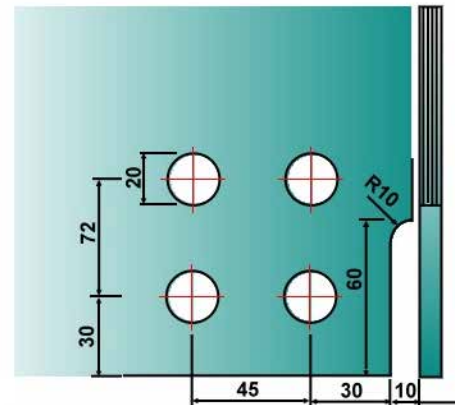
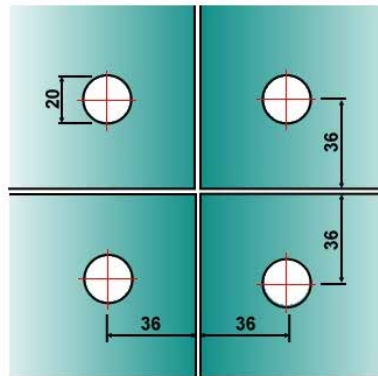
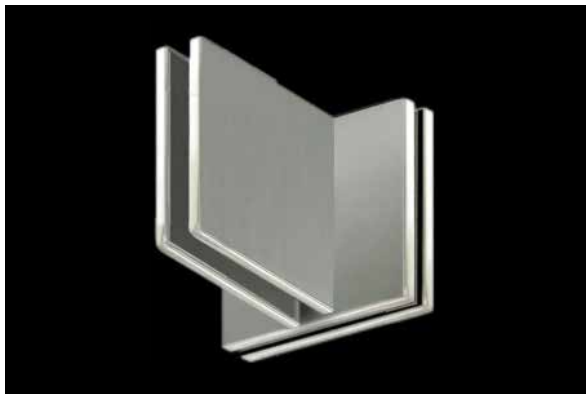

- Application: For swing doors.
- Durable Mechanism, Stainless Steel Cover plate
- Removeable cover plate to minimise on-site damage
- Torsion Test: 400KG
- Horizontal Load on Patch Fitting: 2000KG
- Glass Thickness: 10-12mm / 13.5-15mm
- L\*W\*H : L: 106mm, W: 106mm, H: 31mm
- Life Cycle Test: 500,000 Cycle (Open/Close) (Approved by SISIR-Singapore)

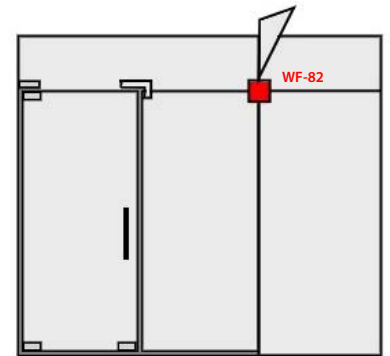

### GUARANTEE

The **WEIDER** Patch Fitting are guaranteed **3 years** from date of manufacture against any defects in material or workmanship. Defective products will be replaced with a new unit; but no claims for damage incurred or work done thereon will be allowed. This guarantee is void if the product has been subjected to misapplication or abuse.



Design by Weider Metal Australia



Weider Metal Inc. reserves the right to make product changes and is not responsible for obsolete template errors. To ensure your template is current, please visit our website at [www.weidermetal.com](http://www.weidermetal.com) or email our sales representatives.

© 2015 Weider Metal Inc. All rights reserved.  
WEIDER METAL AUSTRALIA. WEIDER METAL INC.



## Narrow Style Center Glass Patch Lock WGL-800G

**International  
Patent  
Registered**



### Description

Weider Locks are easy to install and constructed with Stainless steel which is made durable. Hardened steel lock mechanism ensures that Weider lock provides secure locked position at all times. Weider exclusive Auto-Extension dead-bolt with Single throw projection of 20mm / 0.787in and effective projection for hook bolt of 8mm / 0.315in.

### Features and Specifications

- Application: For glass swing and sliding doors.
- Durable Mechanism and Stainless Steel faceplate
- Available in glass to wall, glass to glass
- Backset: 25mm / 0.984in
- Glass thickness: 10 -12mm / 0.394 - 0.472in  
(13.5mm or 15mm / 0.531in or 0.591in ar available upon request)
- Single Throw Dead-bolt distance: 20mm / 0.787in
- Exclusive Auto Extention Hook Bolt distance: 8mm / 0.315in
- Optional adjustable strike box available upon request
- Meets requirement of EN12209
- Life Cycle Test: 250,000 Cycles (Lock/Unlock)

Keying: Available with 3PIN Euro Profile Cylinder:

- Double Key Cylinder
- Single Cylinder w/ Thumbturn
- Bathroom function cylinder

Standard Finishes : Satin Stainless Steel and Polished Stainless Steel

\* Colour Conversion kit available upon request.

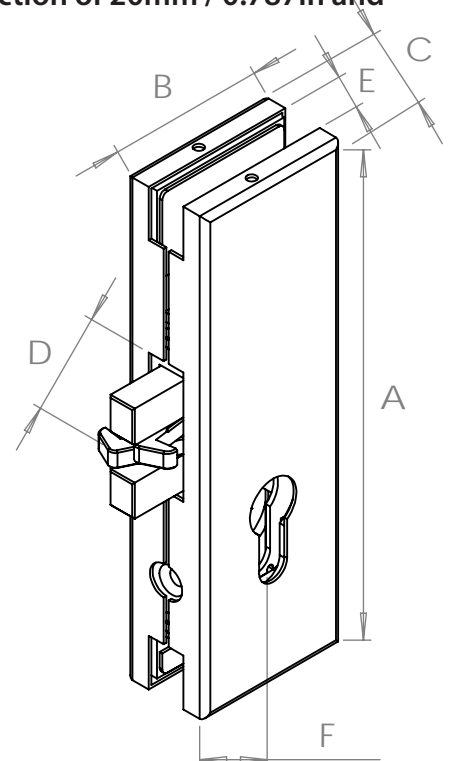



**International Patent Registered**

# Patch Lock WGL-200B

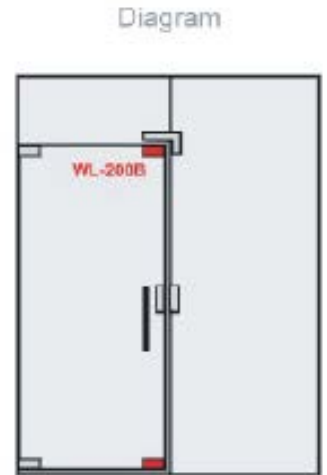

### Description

WEIDER Glass Fitting advantages lie not just in their inherent beauty but also in their innovative design. WEIDER offers a high degree of security and strength. As you go through this information leaflet you will find meticulous attention to detail an uncompromising standard of quality and most importantly simple, elegance and functionality

### Features and Specifications

- Application: For swing doors.
- Durable Mechanism, Stainless Steel Cover plate
- Removeable cover plate to minimise on-site damage
- Single Throw Exclusive Auto Extention Dead-bolt distance: 20mm / 0.787in
- Laminate Stainless Steel with Anti-Saw Protection Technology
- "Mickey Mouse" glass cut-out to reinforce safety to avoid slipping
- Glass Thickness: 10-12mm / 13.5-15mm
- L\*W\*H : 106mm \* 106mm \* 31mm
- Life Cycle Test: 250,000 Cycle (Open/Close) (Approved by SISIR-Singapore)

Standard Finishes : Satin Stainless Steel (SSS) , Polished Stainless Steel(PSS), Titanium Gold (TiG), Aluminium Silver Brush (SNA)  
\* Colour Conversion kit available upon request.

Keying: Available with 5 or 6PIN Tumbler mechanism:

- Double Key Cylinder
- Single Cylinder w/ Thumbturn

WEIDER Micky-Mouse Glass Cutout

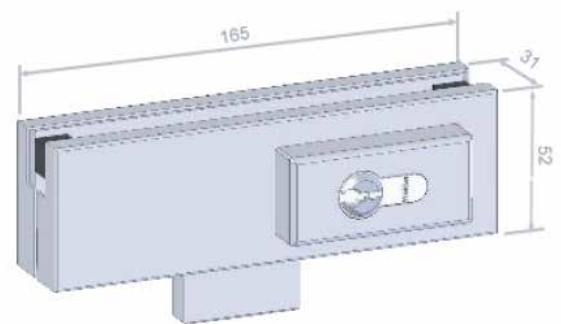
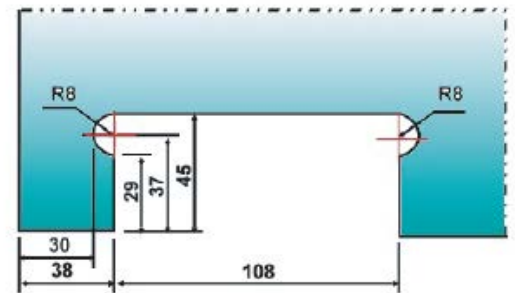

### GUARANTEE

The **WEIDER** Patch Lock WGL-200B are guaranteed **3 years** from date of manufacture against any defects in material or workmanship. Defective products will be replaced with a new unit; but no claims for damage incurred or work done thereon will be allowed. This guarantee is void if the product has been subjected to misapplication or abuse.



Design by Weider Metal Australia



Weider Metal Inc. reserves the right to make product changes and is not responsible for obsolete template errors. To ensure your template is current, please visit our website at [www.weidermetal.com](http://www.weidermetal.com) or email our sales representatives.

© 2015 Weider Metal Inc. All rights reserved.  
**WEIDER METAL AUSTRALIA. WEIDER METAL INC.**





**International Patent Registered**

# Patch Lock WGL-200B/SWP/SQ

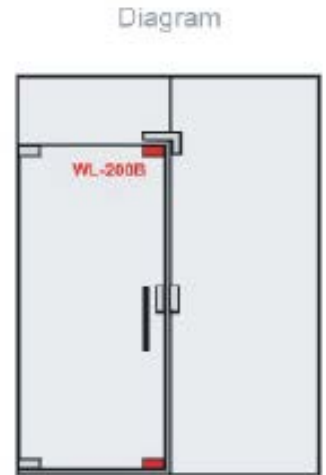

### Description

WEIDER Glass Fitting advantages lie not just in their inherent beauty but also in their innovative design. WEIDER offers a high degree of security and strength. As you go through this information leaflet you will find meticulous attention to detail an uncompromising standard of quality and most importantly simple, elegance and functionality

### Features and Specifications

- Application: For swing doors.
- Durable Mechanism, Stainless Steel Cover plate
- Removeable cover plate to minimise on-site damage
- Single Throw Exclusive Auto Extention Dead-bolt distance: 20mm / 0.787in
- Laminate Stainless Steel with Anti-Saw Protection Technology
- "Mickey Mouse" glass cut-out to reinforce safety to avoid slipping
- Glass Thickness: 10-12mm / 13.5-15mm
- L\*W\*H : 106mm \* 106mm \* 31mm
- Life Cycle Test: 250,000 Cycle (Open/Close) (Approved by SISIR-Singapore)

Standard Finishes : Satin Stainless Steel (SSS) , Polished Stainless Steel(PSS), Titanium Gold (TiG), Aluminium Silver Brush (SNA)

\* Colour Conversion kit available upon request.

Keying: SWISS PROFILE

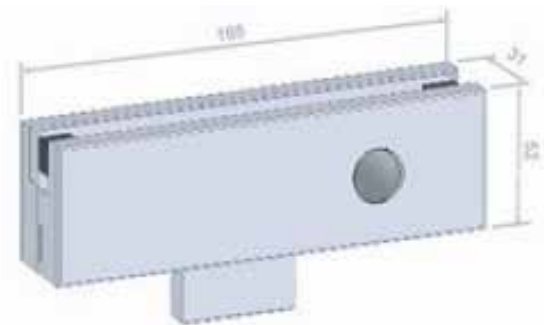
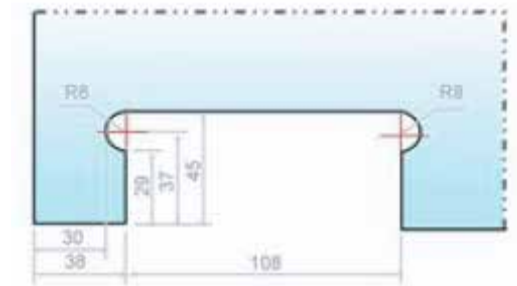

### GUARANTEE

The **WEIDER** Patch Lock WGL-200B/SWP are guaranteed **3 years** from date of manufacture against any defects in material or workmanship. Defective products will be replaced with a new unit; but no claims for damage incurred or work done thereon will be allowed. This guarantee is void if the product has been subjected to misapplication or abuse.



Design by Weider Metal Australia



Weider Metal Inc. reserves the right to make product changes and is not responsible for obsolete template errors. To ensure your template is current, please visit our website at [www.weidermetal.com](http://www.weidermetal.com) or email our sales representatives.

© 2015 Weider Metal Inc. All rights reserved.  
**WEIDER METAL AUSTRALIA. WEIDER METAL INC.**







**International Patent Registered**

# Patch Lock WGL-200B/SWP/CE



### Description

WEIDER Glass Fitting advantages lie not just in their inherent beauty but also in their innovative design. WEIDER offers a high degree of security and strength. As you go through this information leaflet you will find meticulous attention to detail an uncompromising standard of quality and most importantly simple, elegance and functionality

### Features and Specifications

- Application: For swing doors.
- Durable Mechanism, Stainless Steel Cover plate
- Removeable cover plate to minimise on-site damage
- Single Throw Exclusive Auto Extension Dead-bolt distance: 20mm / 0.787in
- Laminate Stainless Steel with Anti-Saw Protection Technology
- "Mickey Mouse" glass cut-out to reinforce safety to avoid slipping
- Glass Thickness: 10-12mm / 13.5-15mm
- L\*W\*H : 106mm \* 106mm \* 31mm
- Life Cycle Test: 250,000 Cycle (Open/Close) (Approved by SISIR-Singapore)

Standard Finishes : Satin Stainless Steel (SSS) , Polished Stainless Steel(PSS), Titanium Gold (TiG), Aluminium Silver Brush (SNA)  
\* Colour Conversion kit available upon request.

Keying: SWISS PROFILE

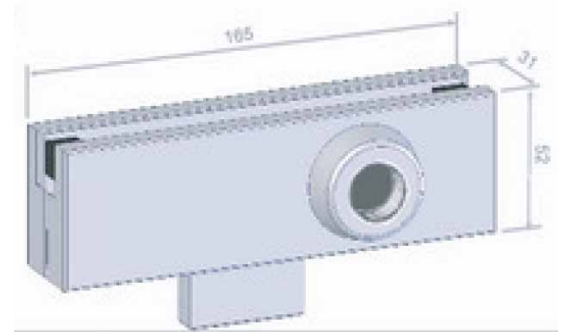
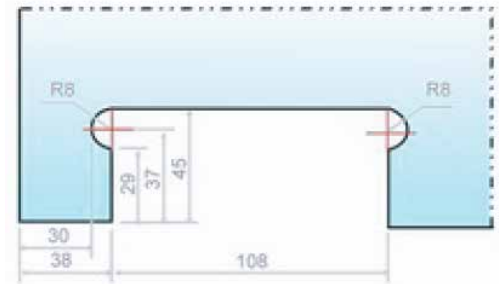

### GUARANTEE

The **WEIDER** Patch Lock WGL-200B/SWP/CE are guaranteed **3 years** from date of manufacture against any defects in material or workmanship. Defective products will be replaced with a new unit; but no claims for damage incurred or work done thereon will be allowed. This guarantee is void if the product has been subjected to misapplication or abuse.



Design by Weider Metal Australia



Weider Metal Inc. reserves the right to make product changes and is not responsible for obsolete template errors. To ensure your template is current, please visit our website at [www.weidermetal.com](http://www.weidermetal.com) or email our sales representatives.

© 2015 Weider Metal Inc. All rights reserved.  
**WEIDER METAL AUSTRALIA. WEIDER METAL INC.**





**International Patent Registered**

# Patch Lock WGL-200B/SWP/SQ



### Description

WEIDER Glass Fitting advantages lie not just in their inherent beauty but also in their innovative design. WEIDER offers a high degree of security and strength. As you go through this information leaflet you will find meticulous attention to detail an uncompromising standard of quality and most importantly simple, elegance and functionality

### Features and Specifications

- Application: For swing doors.
- Durable Mechanism, Stainless Steel Cover plate
- Removeable cover plate to minimise on-site damage
- Single Throw Exclusive Auto Extention Dead-bolt distance: 20mm / 0.787in
- Laminate Stainless Steel with Anti-Saw Protection Technology
- "Mickey Mouse" glass cut-out to reinforce safety to avoid slipping
- Glass Thickness: 10-12mm / 13.5-15mm
- L\*W\*H : 106mm \* 106mm \* 31mm
- Life Cycle Test: 250,000 Cycle (Open/Close) (Approved by SISIR-Singapore)

Standard Finishes : Satin Stainless Steel (SSS) , Polished Stainless Steel(PSS), Titanium Gold (TiG), Aluminium Silver Brush (SNA)  
\* Colour Conversion kit available upon request.

Keying: SWISS PROFILE

Glass preparation

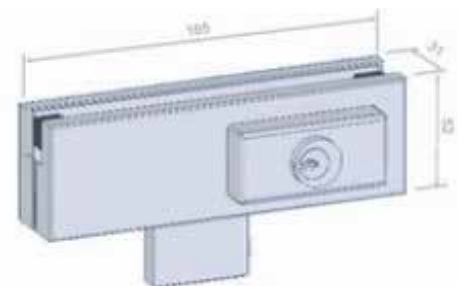

### GUARANTEE

The **WEIDER** Patch Lock WGL-200B/SWP/SQ are guaranteed **3 years** from date of manufacture against any defects in material or workmanship. Defective products will be replaced with a new unit; but no claims for damage incurred or work done thereon will be allowed. This guarantee is void if the product has been subjected to misapplication or abuse.



Design by Weider Metal Australia



Weider Metal Inc. reserves the right to make product changes and is not responsible for obsolete template errors. To ensure your template is current, please visit our website at [www.weidermetal.com](http://www.weidermetal.com) or email our sales representatives.

© 2015 Weider Metal Inc. All rights reserved.  
**WEIDER METAL AUSTRALIA. WEIDER METAL INC.**





**International Patent Registered**

# Patch Lock WGL-200C



### Description

WEIDER Glass Fitting advantages lie not just in their inherent beauty but also in their innovative design. WEIDER offers a high degree of security and strength. As you go through this information leaflet you will find meticulous attention to detail an uncompromising standard of quality and most importantly simple, elegance and functionality

### Features and Specifications

- Application: For swing doors.
- Durable Mechanism, Stainless Steel Cover plate
- Removeable cover plate to minimise on-site damage
- Single Throw Exclusive Auto Extention Dead-bolt distance: 20mm / 0.787in
- Laminate Stainless Steel with Anti-Saw Protection Technology
- "Mickey Mouse" glass cut-out to reinforce safety to avoid slipping
- Glass Thickness: 10-12mm / 13.5-15mm
- L\*W\*H : 106mm \* 106mm \* 31mm
- Life Cycle Test: 250,000 Cycle (Open/Close) (Approved by SISIR-Singapore)

Standard Finishes : Satin Stainless Steel (SSS) , Polished Stainless Steel(PSS), Titanium Gold (TiG), Aluminium Silver Brush (SNA)  
\* Colour Conversion kit available upon request.

Keying: EURO PROFILE



### GUARANTEE

The **WEIDER** Patch Lock WGL-200C are guaranteed **3 years** from date of manufacture against any defects in material or workmanship. Defective products will be replaced with a new unit; but no claims for damage incurred or work done thereon will be allowed. This guarantee is void if the product has been subjected to misapplication or abuse.



Design by Weider Metal Australia



Weider Metal Inc. reserves the right to make product changes and is not responsible for obsolete template errors. To ensure your template is current, please visit our website at [www.weidermetal.com](http://www.weidermetal.com) or email our sales representatives.

© 2015 Weider Metal Inc. All rights reserved.  
**WEIDER METAL AUSTRALIA. WEIDER METAL INC.**





**International Patent Registered**

# Patch Lock WGL-200C/SWP



### Description

WEIDER Glass Fitting advantages lie not just in their inherent beauty but also in their innovative design. WEIDER offers a high degree of security and strength. As you go through this information leaflet you will find meticulous attention to detail an uncompromising standard of quality and most importantly simple, elegance and functionality

### Features and Specifications

- Application: For swing doors.
- Durable Mechanism, Stainless Steel Cover plate
- Removeable cover plate to minimise on-site damage
- Single Throw Exclusive Auto Extention Dead-bolt distance: 20mm / 0.787in
- Laminate Stainless Steel with Anti-Saw Protection Technology
- "Mickey Mouse" glass cut-out to reinforce safety to avoid slipping
- Glass Thickness: 10-12mm / 13.5-15mm
- L\*W\*H : 106mm \* 106mm \* 31mm
- Life Cycle Test: 250,000 Cycle (Open/Close) (Approved by SISIR-Singapore)

Standard Finishes : Satin Stainless Steel (SSS) , Polished Stainless Steel(PSS), Titanium Gold (TiG), Aluminium Silver Brush (SNA)  
\* Colour Conversion kit available upon request.

Keying: SWISS PROFILE

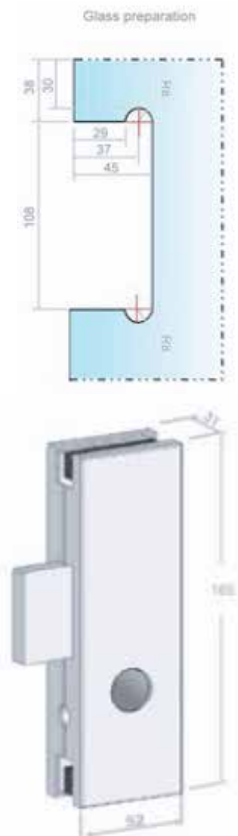

### GUARANTEE

The **WEIDER** Patch Lock WGL-200C/SWP are guaranteed **3 years** from date of manufacture against any defects in material or workmanship. Defective products will be replaced with a new unit; but no claims for damage incurred or work done thereon will be allowed. This guarantee is void if the product has been subjected to misapplication or abuse.



Design by Weider Metal Australia



Weider Metal Inc. reserves the right to make product changes and is not responsible for obsolete template errors. To ensure your template is current, please visit our website at [www.weidermetal.com](http://www.weidermetal.com) or email our sales representatives.

© 2015 Weider Metal Inc. All rights reserved.  
**WEIDER METAL AUSTRALIA. WEIDER METAL INC.**





**International Patent Registered**

# Patch Lock WGL-200C/SWP/CE

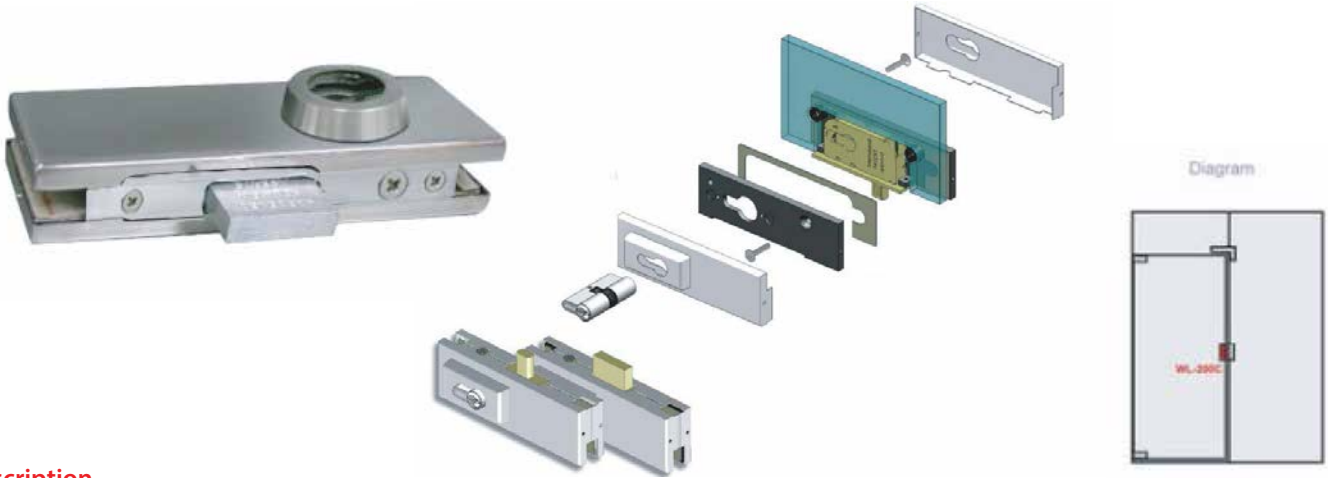

### Description

WEIDER Glass Fitting advantages lie not just in their inherent beauty but also in their innovative design. WEIDER offers a high degree of security and strength. As you go through this information leaflet you will find meticulous attention to detail an uncompromising standard of quality and most importantly simple, elegance and functionality

### Features and Specifications

- Application: For swing doors.
- Durable Mechanism, Stainless Steel Cover plate
- Removeable cover plate to minimise on-site damage
- Single Throw Exclusive Auto Extention Dead-bolt distance: 20mm / 0.787in
- Laminate Stainless Steel with Anti-Saw Protection Technology
- "Mickey Mouse" glass cut-out to reinforce safety to avoid slipping
- Glass Thickness: 10-12mm / 13.5-15mm
- L\*W\*H : 106mm \* 106mm \* 31mm
- Life Cycle Test: 250,000 Cycle (Open/Close) (Approved by SISIR-Singapore)

Standard Finishes : Satin Stainless Steel (SSS) , Polished Stainless Steel(PSS), Titanium Gold (TiG), Aluminium Silver Brush (SNA)

\* Colour Conversion kit available upon request.

Keying: EURO PROFILE

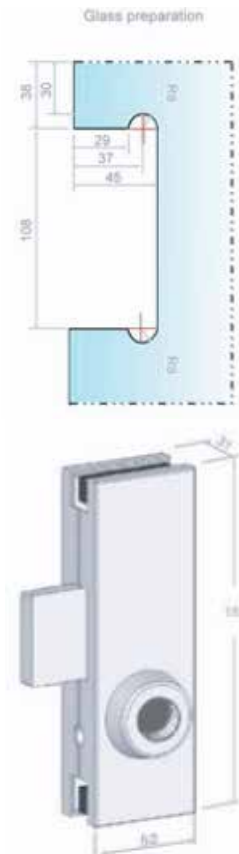

### GUARANTEE

The **WEIDER** Patch Lock WGL-200C/SWP/CE are guaranteed **3 years** from date of manufacture against any defects in material or workmanship. Defective products will be replaced with a new unit; but no claims for damage incurred or work done thereon will be allowed. This guarantee is void if the product has been subjected to misapplication or abuse.



Design by Weider Metal Australia



Weider Metal Inc. reserves the right to make product changes and is not responsible for obsolete template errors. To ensure your template is current, please visit our website at [www.weidermetal.com](http://www.weidermetal.com) or email our sales representatives.

© 2015 Weider Metal Inc. All rights reserved.  
**WEIDER METAL AUSTRALIA. WEIDER METAL INC.**





**International Patent Registered**

# Patch Lock WGL-200C/SWP/SQ



### Description

WEIDER Glass Fitting advantages lie not just in their inherent beauty but also in their innovative design. WEIDER offers a high degree of security and strength. As you go through this information leaflet you will find meticulous attention to detail an uncompromising standard of quality and most importantly simple, elegance and functionality

### Features and Specifications

- Application: For swing doors.
- Durable Mechanism, Stainless Steel Cover plate
- Removeable cover plate to minimise on-site damage
- Single Throw Exclusive Auto Extention Dead-bolt distance: 20mm / 0.787in
- Laminate Stainless Steel with Anti-Saw Protection Technology
- "Mickey Mouse" glass cut-out to reinforce safety to avoid slipping
- Glass Thickness: 10-12mm / 13.5-15mm
- L\*W\*H : 106mm \* 106mm \* 31mm
- Life Cycle Test: 250,000 Cycle (Open/Close) (Approved by SISIR-Singapore)

Standard Finishes : Satin Stainless Steel (SSS) , Polished Stainless Steel(PSS), Titanium Gold (TiG), Aluminium Silver Brush (SNA)  
\* Colour Conversion kit available upon request.

Keying: SWISS PROFILE

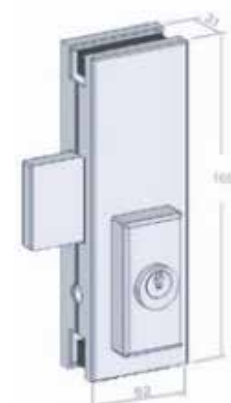
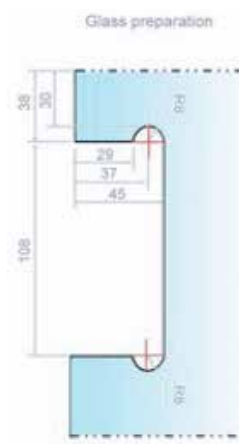

### GUARANTEE

The **WEIDER** Patch Lock WGL-200C/SWP/SQ are guaranteed **3 years** from date of manufacture against any defects in material or workmanship. Defective products will be replaced with a new unit; but no claims for damage incurred or work done thereon will be allowed. This guarantee is void if the product has been subjected to misapplication or abuse.



Design by Weider Metal Australia



Weider Metal Inc. reserves the right to make product changes and is not responsible for obsolete template errors. To ensure your template is current, please visit our website at [www.weidermetal.com](http://www.weidermetal.com) or email our sales representatives.

© 2015 Weider Metal Inc. All rights reserved.  
**WEIDER METAL AUSTRALIA. WEIDER METAL INC.**





**International Patent Registered**

# Patch Lock WGL-500B



### Description

WEIDER Glass Fitting advantages lie not just in their inherent beauty but also in their innovative design. WEIDER offers a high degree of security and strength. As you go through this information leaflet you will find meticulous attention to detail an uncompromising standard of quality and most importantly simple, elegance and functionality

### Features and Specifications

- Application: For swing doors.
- Durable Mechanism, Stainless Steel Cover plate
- Removeable cover plate to minimise on-site damage
- Single Throw Exclusive Auto Extention Dead-bolt distance: 20mm / 0.787in
- Laminate Stainless Steel with Anti-Saw Protection Technology
- "Mickey Mouse" glass cut-out to reinforce safety to avoid slipping
- Glass Thickness: 10-12mm / 13.5-15mm
- L\*W\*H : 106mm \* 106mm \* 31mm
- Life Cycle Test: 250,000 Cycle (Open/Close) (Approved by SISIR-Singapore)

Standard Finishes : Satin Stainless Steel (SSS) , Polished Stainless Steel(PSS), Titanium Gold (TiG), Aluminium Silver Brush (SNA)

\* Colour Conversion kit available upon request.

Keying: Available with 5 or 6PIN Tumbler mechanism:

- Double Key Cylinder
- Single Cylinder w/ Thumbturn

WEIDER Micky-Mouse Glass Cutout

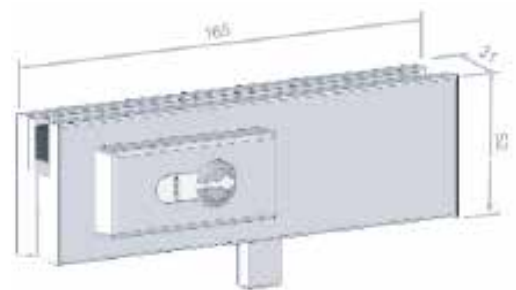
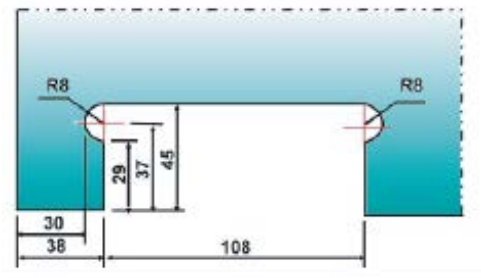

### GUARANTEE

The WEIDER Patch Lock WGL-500B are guaranteed **3 years** from date of manufacture against any defects in material or workmanship. Defective products will be replaced with a new unit; but no claims for damage incurred or work done thereon will be allowed. This guarantee is void if the product has been subjected to misapplication or abuse.



Design by Weider Metal Australia



Weider Metal Inc. reserves the right to make product changes and is not responsible for obsolete template errors. To ensure your template is current, please visit our website at [www.weidermetal.com](http://www.weidermetal.com) or email our sales representatives.

© 2015 Weider Metal Inc. All rights reserved.  
WEIDER METAL AUSTRALIA. WEIDER METAL INC.





**International Patent Registered**

# Patch Lock WGL-500B/SWP

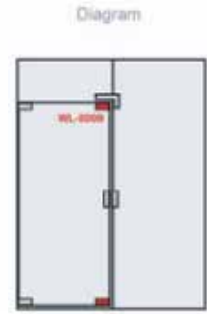

### Description

WEIDER Glass Fitting advantages lie not just in their inherent beauty but also in their innovative design. WEIDER offers a high degree of security and strength. As you go through this information leaflet you will find meticulous attention to detail an uncompromising standard of quality and most importantly simple, elegance and functionality

### Features and Specifications

- Application: For swing doors.
- Durable Mechanism, Stainless Steel Cover plate
- Removeable cover plate to minimise on-site damage
- Single Throw Exclusive Auto Extention Dead-bolt distance: 20mm / 0.787in
- Laminate Stainless Steel with Anti-Saw Protection Technology
- "Mickey Mouse" glass cut-out to reinforce safety to avoid slipping
- Glass Thickness: 10-12mm / 13.5-15mm
- L\*W\*H : 106mm \* 106mm \* 31mm
- Life Cycle Test: 250,000 Cycle (Open/Close) (Approved by SISIR-Singapore)

Glass preparation

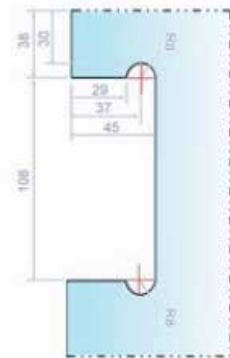

Standard Finishes : Satin Stainless Steel (SSS) , Polished Stainless Steel(PSS), Titanium Gold (TiG), Aluminium Silver Brush (SNA)  
\* Colour Conversion kit available upon request.

Keying: SWISS PROFILE



### GUARANTEE

The **WEIDER** Patch Lock WGL-500B/SWP are guaranteed **3 years** from date of manufacture against any defects in material or workmanship. Defective products will be replaced with a new unit; but no claims for damage incurred or work done thereon will be allowed. This guarantee is void if the product has been subjected to misapplication or abuse.



Design by Weider Metal Australia



Weider Metal Inc. reserves the right to make product changes and is not responsible for obsolete template errors. To ensure your template is current, please visit our website at [www.weidermetal.com](http://www.weidermetal.com) or email our sales representatives.

© 2015 Weider Metal Inc. All rights reserved.  
**WEIDER METAL AUSTRALIA. WEIDER METAL INC.**







**International Patent Registered**

# Patch Lock WGL-500B/SWP/CE

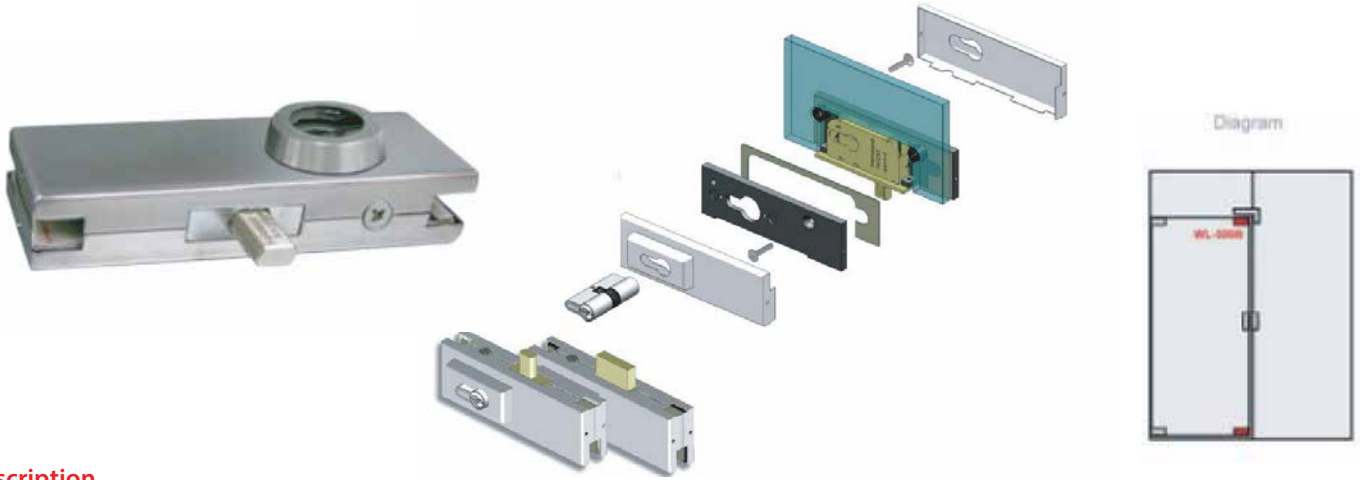

### Description

WEIDER Glass Fitting advantages lie not just in their inherent beauty but also in their innovative design. WEIDER offers a high degree of security and strength. As you go through this information leaflet you will find meticulous attention to detail an uncompromising standard of quality and most importantly simple, elegance and functionality

### Features and Specifications

- Application: For swing doors.
- Durable Mechanism, Stainless Steel Cover plate
- Removeable cover plate to minimise on-site damage
- Single Throw Exclusive Auto Extention Dead-bolt distance: 20mm / 0.787in
- Laminate Stainless Steel with Anti-Saw Protection Technology
- "Mickey Mouse" glass cut-out to reinforce safety to avoid slipping
- Glass Thickness: 10-12mm / 13.5-15mm
- L\*W\*H : 106mm \* 106mm \* 31mm
- Life Cycle Test: 250,000 Cycle (Open/Close) (Approved by SISIR-Singapore)

Standard Finishes : Satin Stainless Steel (SSS) , Polished Stainless Steel(PSS), Titanium Gold (TiG), Aluminium Silver Brush (SNA)  
\* Colour Conversion kit available upon request.

Keying: SWISS PROFILE

Glass preparation

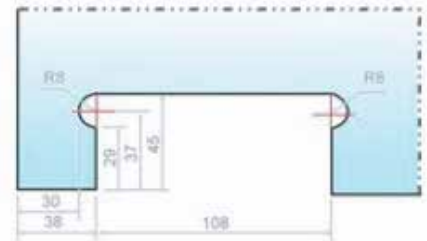

### GUARANTEE

The **WEIDER** Patch Lock WGL-500B/SWP/CE are guaranteed **3 years** from date of manufacture against any defects in material or workmanship. Defective products will be replaced with a new unit; but no claims for damage incurred or work done thereon will be allowed. This guarantee is void if the product has been subjected to misapplication or abuse.



Design by Weider Metal Australia



Weider Metal Inc. reserves the right to make product changes and is not responsible for obsolete template errors. To ensure your template is current, please visit our website at [www.weidermetal.com](http://www.weidermetal.com) or email our sales representatives.

© 2015 Weider Metal Inc. All rights reserved.  
**WEIDER METAL AUSTRALIA. WEIDER METAL INC.**





**International Patent Registered**

# Patch Lock WGL-500B/SWP/SQ



### Description

WEIDER Glass Fitting advantages lie not just in their inherent beauty but also in their innovative design. WEIDER offers a high degree of security and strength. As you go through this information leaflet you will find meticulous attention to detail an uncompromising standard of quality and most importantly simple, elegance and functionality

### Features and Specifications

- Application: For swing doors.
- Durable Mechanism, Stainless Steel Cover plate
- Removeable cover plate to minimise on-site damage
- Single Throw Exclusive Auto Extention Dead-bolt distance: 20mm / 0.787in
- Laminate Stainless Steel with Anti-Saw Protection Technology
- "Mickey Mouse" glass cut-out to reinforce safety to avoid slipping
- Glass Thickness: 10-12mm / 13.5-15mm
- L\*W\*H : 106mm \* 106mm \* 31mm
- Life Cycle Test: 250,000 Cycle (Open/Close) (Approved by SISIR-Singapore)

Standard Finishes : Satin Stainless Steel (SSS) , Polished Stainless Steel(PSS), Titanium Gold (TiG), Aluminium Silver Brush (SNA)  
\* Colour Conversion kit available upon request.

Keying: SWISS PROFILE

Glass preparation

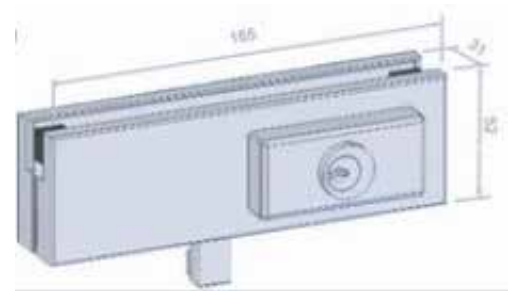
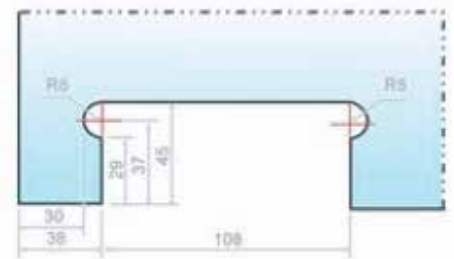

### GUARANTEE

The **WEIDER** Patch Lock WGL-500B/SWP/SQ are guaranteed **3 years** from date of manufacture against any defects in material or workmanship. Defective products will be replaced with a new unit; but no claims for damage incurred or work done thereon will be allowed. This guarantee is void if the product has been subjected to misapplication or abuse.



Design by Weider Metal Australia



Weider Metal Inc. reserves the right to make product changes and is not responsible for obsolete template errors. To ensure your template is current, please visit our website at [www.weidermetal.com](http://www.weidermetal.com) or email our sales representatives.

© 2015 Weider Metal Inc. All rights reserved.  
**WEIDER METAL AUSTRALIA. WEIDER METAL INC.**





**International Patent Registered**

# Patch Lock WGL-500C

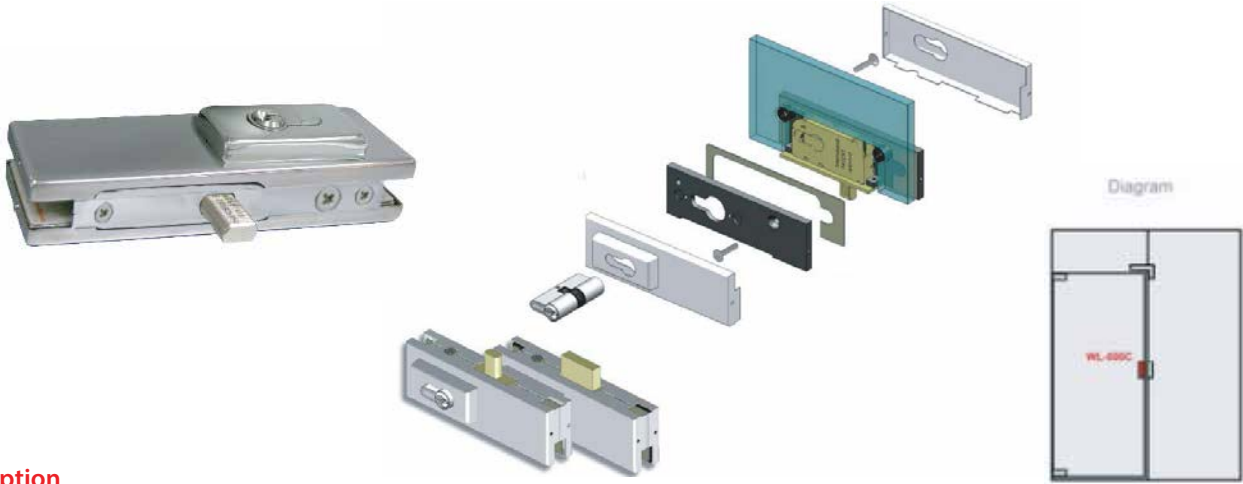

### Description

WEIDER Glass Fitting advantages lie not just in their inherent beauty but also in their innovative design. WEIDER offers a high degree of security and strength. As you go through this information leaflet you will find meticulous attention to detail an uncompromising standard of quality and most importantly simple, elegance and functionality

### Features and Specifications

- Application: For swing doors.
- Durable Mechanism, Stainless Steel Cover plate
- Removeable cover plate to minimise on-site damage
- Single Throw Exclusive Auto Extention Dead-bolt distance: 20mm / 0.787in
- Laminate Stainless Steel with Anti-Saw Protection Technology
- "Mickey Mouse" glass cut-out to reinforce safety to avoid slipping
- Glass Thickness: 10-12mm / 13.5-15mm
- L\*W\*H : 106mm \* 106mm \* 31mm
- Life Cycle Test: 250,000 Cycle (Open/Close) (Approved by SISIR-Singapore)

Standard Finishes : Satin Stainless Steel (SSS) , Polished Stainless Steel(PSS), Titanium Gold (TiG), Aluminium Silver Brush (SNA)  
\* Colour Conversion kit available upon request.

Keying: EURO PROFILE

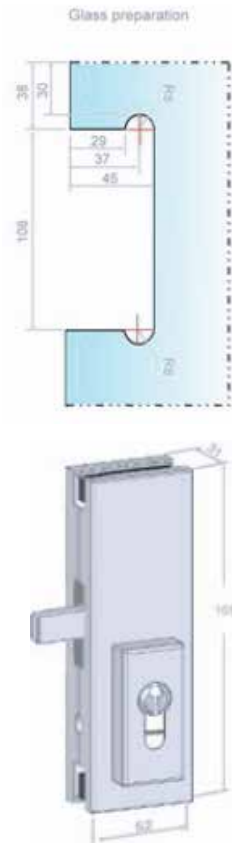

### GUARANTEE

The **WEIDER** Patch Lock WGL-500C are guaranteed **3 years** from date of manufacture against any defects in material or workmanship. Defective products will be replaced with a new unit; but no claims for damage incurred or work done thereon will be allowed. This guarantee is void if the product has been subjected to misapplication or abuse.



Design by Weider Metal Australia



Weider Metal Inc. reserves the right to make product changes and is not responsible for obsolete template errors. To ensure your template is current, please visit our website at [www.weidermetal.com](http://www.weidermetal.com) or email our sales representatives.

© 2015 Weider Metal Inc. All rights reserved.  
**WEIDER METAL AUSTRALIA. WEIDER METAL INC.**





**International Patent Registered**

# Patch Lock WGL-500C/SWP



### Description

WEIDER Glass Fitting advantages lie not just in their inherent beauty but also in their innovative design. WEIDER offers a high degree of security and strength. As you go through this information leaflet you will find meticulous attention to detail an uncompromising standard of quality and most importantly simple, elegance and functionality

### Features and Specifications

- Application: For swing doors.
- Durable Mechanism, Stainless Steel Cover plate
- Removeable cover plate to minimise on-site damage
- Single Throw Exclusive Auto Extention Dead-bolt distance: 20mm / 0.787in
- Laminate Stainless Steel with Anti-Saw Protection Technology
- "Mickey Mouse" glass cut-out to reinforce safety to avoid slipping
- Glass Thickness: 10-12mm / 13.5-15mm
- L\*W\*H : 106mm \* 106mm \* 31mm
- Life Cycle Test: 250,000 Cycle (Open/Close) (Approved by SISIR-Singapore)

Standard Finishes : Satin Stainless Steel (SSS) , Polished Stainless Steel(PSS), Titanium Gold (TiG), Aluminium Silver Brush (SNA)

\* Colour Conversion kit available upon request.

Keying: SWISS PROFILE

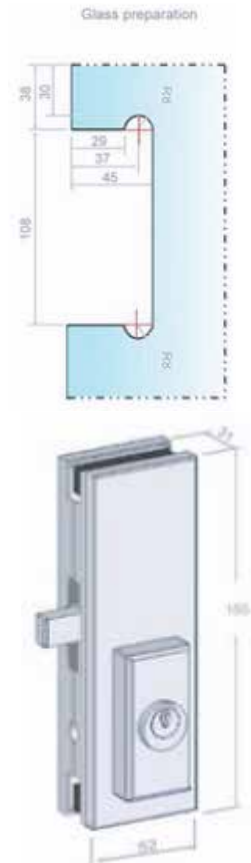

### GUARANTEE

The **WEIDER** Patch Lock WGL-500C/SWP are guaranteed **3 years** from date of manufacture against any defects in material or workmanship. Defective products will be replaced with a new unit; but no claims for damage incurred or work done thereon will be allowed. This guarantee is void if the product has been subjected to misapplication or abuse.



Design by Weider Metal Australia



Weider Metal Inc. reserves the right to make product changes and is not responsible for obsolete template errors. To ensure your template is current, please visit our website at [www.weidermetal.com](http://www.weidermetal.com) or email our sales representatives.

© 2015 Weider Metal Inc. All rights reserved.  
**WEIDER METAL AUSTRALIA. WEIDER METAL INC.**





**International Patent Registered**

# Patch Lock WGL-500C/SWP/CE



### Description

WEIDER Glass Fitting advantages lie not just in their inherent beauty but also in their innovative design. WEIDER offers a high degree of security and strength. As you go through this information leaflet you will find meticulous attention to detail an uncompromising standard of quality and most importantly simple, elegance and functionality

### Features and Specifications

- Application: For swing doors.
- Durable Mechanism, Stainless Steel Cover plate
- Removeable cover plate to minimise on-site damage
- Single Throw Exclusive Auto Extention Dead-bolt distance: 20mm / 0.787in
- Laminate Stainless Steel with Anti-Saw Protection Technology
- "Mickey Mouse" glass cut-out to reinforce safety to avoid slipping
- Glass Thickness: 10-12mm / 13.5-15mm
- L\*W\*H : 106mm \* 106mm \* 31mm
- Life Cycle Test: 250,000 Cycle (Open/Close) (Approved by SISIR-Singapore)

Standard Finishes : Satin Stainless Steel (SSS) , Polished Stainless Steel(PSS), Titanium Gold (TiG), Aluminium Silver Brush (SNA)

\* Colour Conversion kit available upon request.

Keying: SWISS PROFILE

Glass preparation

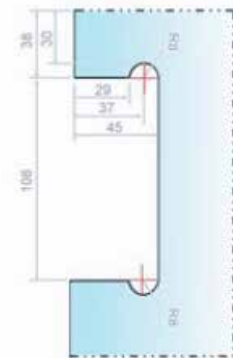

### GUARANTEE

The **WEIDER** Patch Lock WGL-500C/SWP/CE are guaranteed **3 years** from date of manufacture against any defects in material or workmanship. Defective products will be replaced with a new unit; but no claims for damage incurred or work done thereon will be allowed. This guarantee is void if the product has been subjected to misapplication or abuse.



Design by Weider Metal Australia



Weider Metal Inc. reserves the right to make product changes and is not responsible for obsolete template errors. To ensure your template is current, please visit our website at [www.weidermetal.com](http://www.weidermetal.com) or email our sales representatives.

© 2015 Weider Metal Inc. All rights reserved.  
**WEIDER METAL AUSTRALIA. WEIDER METAL INC.**





**International Patent Registered**

# Patch Lock WGL-500C/SWP/SQ



### Description

WEIDER Glass Fitting advantages lie not just in their inherent beauty but also in their innovative design. WEIDER offers a high degree of security and strength. As you go through this information leaflet you will find meticulous attention to detail an uncompromising standard of quality and most importantly simple, elegance and functionality

### Features and Specifications

- Application: For swing doors.
- Durable Mechanism, Stainless Steel Cover plate
- Removeable cover plate to minimise on-site damage
- Single Throw Exclusive Auto Extention Dead-bolt distance: 20mm / 0.787in
- Laminate Stainless Steel with Anti-Saw Protection Technology
- "Mickey Mouse" glass cut-out to reinforce safety to avoid slipping
- Glass Thickness: 10-12mm / 13.5-15mm
- L\*W\*H : 106mm \* 106mm \* 31mm
- Life Cycle Test: 250,000 Cycle (Open/Close) (Approved by SISIR-Singapore)

Standard Finishes : Satin Stainless Steel (SSS) , Polished Stainless Steel(PSS), Titanium Gold (TiG), Aluminium Silver Brush (SNA)  
\* Colour Conversion kit available upon request.

Keying: SWISS PROFILE

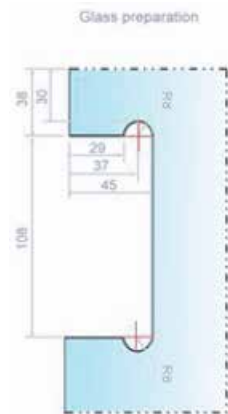

### GUARANTEE

The **WEIDER** Patch Lock WGL-500C/SWP/SQ are guaranteed **3 years** from date of manufacture against any defects in material or workmanship. Defective products will be replaced with a new unit; but no claims for damage incurred or work done thereon will be allowed. This guarantee is void if the product has been subjected to misapplication or abuse.

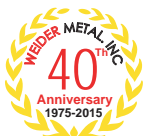

Design by Weider Metal Australia



Weider Metal Inc. reserves the right to make product changes and is not responsible for obsolete template errors. To ensure your template is current, please visit our website at [www.weidermetal.com](http://www.weidermetal.com) or email our sales representatives.

© 2015 Weider Metal Inc. All rights reserved.  
**WEIDER METAL AUSTRALIA. WEIDER METAL INC.**



**Accessories for Tempered Glass Entrances**

**Art. No. 725-25 Pivot**  
with threaded rod including  
brass wall plug.

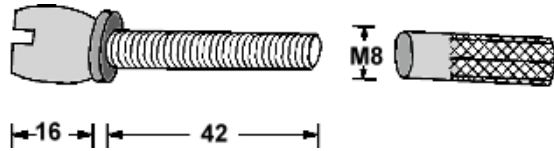

**Art. No. 725-24**  
**15 mm Pivot**  
with stainless steel fixing plate

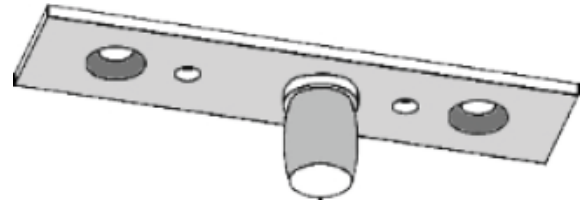

**Art. No. 725-15 SSS**  
**Top Centre with 15 mm pin**

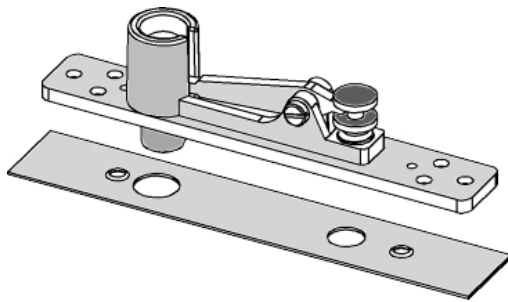

**Art. No. 725-20**  
**Pivot insert**  
with nylon bush (WF-20)

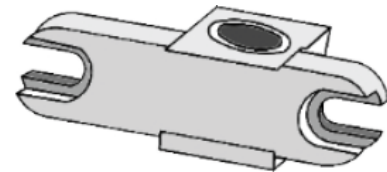

**Art. No. 725-10**  
**Stainless steel bottom insert**

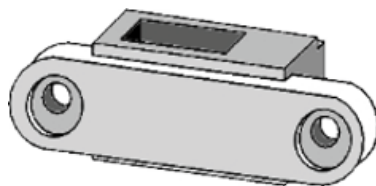

**Art. No. 725-30**  
**Pivot insert with 15 mm pin**  
for overpanel fitting (WF-30 and WF-40)

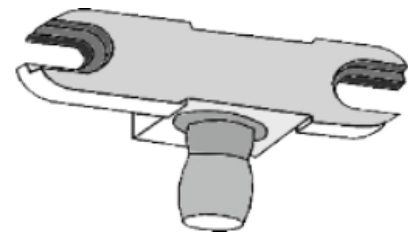

**GUARANTEE**

The **WEIDER** Accessories for tempered glass entrances are guaranteed **2 years** from date of manufacture against any defects in material or workmanship. Defective products will be replaced with a new unit; but no claims for damage incurred or work done thereon will be allowed. This guarantee is void if the product has been subjected to misapplication or abuse.



Design by Weider Metal Australia



Weider Metal Inc. reserves the right to make product changes and is not responsible for obsolete template errors. To ensure your template is current, please visit our website at [www.weidermetal.com](http://www.weidermetal.com) or email our sales representatives. Z:\013-目錄\_Weider Catalogue\013-Weider Patch Fitting

© 2015 Weider Metal Inc. All rights reserved.  
**WEIDER METAL AUSTRALIA. WEIDER METAL INC.**



**Accessories for Tempered Glass Entrances**

**Art. No. 725-10x15  
Easy clean sockets**

available in bright chrome finish & brass colour finish

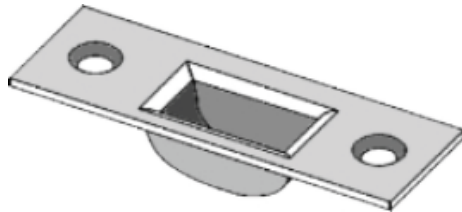

**Art. No. 725-100  
Easy clean sockets**

available in bright chrome finish & brass colour finish

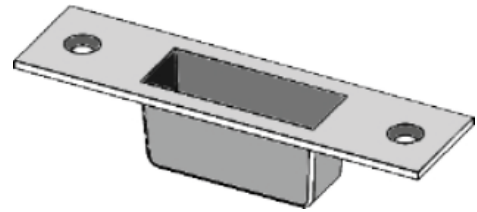

**DP-15  
Dust-Proof Strike**

Finishes:  
Chrome plated - CP  
Polished brass - PB



**Art. No. 7062 Adjustable lower part for Top Rail**

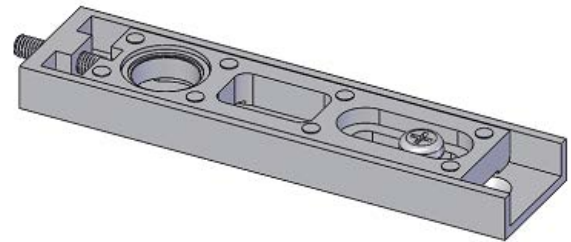

**Art. No. 725-8  
Bottom Floor Pivot**

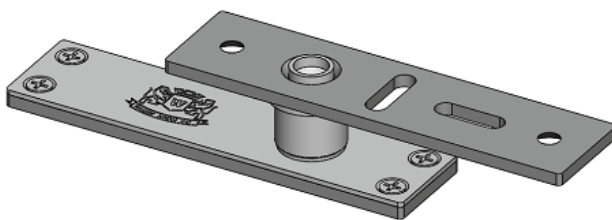

**GUARANTEE**

The **WEIDER** Accessories for tempered glass entrances are guaranteed **2 years** from date of manufacture against any defects in material or workmanship. Defective products will be replaced with a new unit; but no claims for damage incurred or work done thereon will be allowed. This guarantee is void if the product has been subjected to misapplication or abuse.



Design by Weider Metal Australia



Weider Metal Inc. reserves the right to make product changes and is not responsible for obsolete template errors. To ensure your template is current, please visit our website at [www.weidermetal.com](http://www.weidermetal.com) or email our sales representatives. Z:\013-目錄\_Weider Catalogue\013-Weider Patch Fitting

© 2015 Weider Metal Inc. All rights reserved.  
**WEIDER METAL AUSTRALIA. WEIDER METAL INC.**

